

## Comparative trials of manual mine clearance techniques Mozambique, 2004



A report for the  
Geneva International Centre for Humanitarian Demining  
December 2004

## Acknowledgements

***This report has been compiled for GICHD by an external consultant (Andy Smith). GICHD can accept no responsibility for errors or omissions of fact or opinion throughout this document.***

***Without the committed assistance of ADP management and staff, these trials could not have been conducted.***



Accelerated Demining  
Programme (ADP)

The trial was devised and implemented by Andy Smith (AVS), with valuable advice and input from all persons/organisations participating in the planning, monitoring and evaluation, especially the representatives from BAM and QinetiQ:

Jacky D'Almeda, Florencio Chongo: ADP Mozambique  
Manuel R. Django, Paulino Tule Gove: ADP Mozambique  
Mate Gaal, Christina Mueller, BAM  
Neville Goulton, Dai Lewis: QinetiQ

Jan Eric Stoa, Luke Atkinson: NPA Sri Lanka  
Sara Sekkenes, Hans Rune Kampenhøy: NPA Mozambique  
Tim Lardner, Havard Bach: GICHD  
Dieter Guelle



The following ADP field supervisors and deminers worked selflessly to support the trials:

Fernando Laice,  
Dionisio Chaka,  
Julio Ernesto Wache,  
Carlos Tembe,  
Januario Justino Mindo,  
Helder Martins Adido,  
Manuel Abilio Balate.

## Terms, definitions and abbreviations

Familiarity with acronyms commonly used in Humanitarian Demining is presumed.

**area-excavation:** in this report, the term “**area-excavation**” is used to describe the process of removing the entire ground surface to a predetermined depth, and locating any concealed mines or ERW in the process.

**detector-signal investigation:** in this report, the term “**detector-signal investigation**” is used to describe the process of locating metal with a metal-detector, then unearthing and recovering that metal from a discrete location.

**REDS** – Rake Excavation and Detection System, as devised by NPA with the HDU in Sri Lanka

**GRH** – Ground Reference Height: a measure of electromagnetic disturbance from the ground.

## Contents

1	Foreword .....	6
2	Introduction.....	6
3	Comparative trials in Mozambique.....	6
3.1	Aims .....	7
3.1.1	Limitations to aims .....	7
3.2	Trial conditions.....	7
3.2.1	Total trial area .....	8
3.3	Trial duration .....	8
3.4	Targets .....	9
3.5	Recording data.....	10
3.6	Trial Monitor’s duties .....	11
4	Manual demining systems under assessment.....	12
4.1	Standard method (Trial 1).....	12
4.2	Standard plus magnet-clip on tool (Trial 2).....	13
4.3	Standard plus MBR (Magnet Brush-rake) – Trial 3.....	14
4.4	Detector in low-fragment area (Trial 4).....	15
4.4.1	The “reliability” part of Trial 4.....	15
4.5	The REDS rake system (Trial 5).....	16
4.6	Standard ADP spade excavation (Trial 6) .....	17
4.7	Standard NPA (Mozambique) excavation (Trial 7) .....	18
4.8	Standard Mattock excavation (Trial 8) .....	19
4.9	Prodding (Trial 9) .....	20
5	Results .....	21
5.1	Results: Standard metal-detector method (Trial 1).....	23
5.2	Results: Standard plus magnet-clip on tool (Trial 2).....	24
5.3	Results: Standard plus MBR (Magnet Brush-rake) – Trial 3 .....	26
5.4	Results: Detector in low fragment area (Trial 4) .....	28
5.4.1	Results of the “reliability” part of Trial 4 .....	29
5.5	Results: The REDS rake system (Trial 5).....	30
5.6	Results: Standard ADP spade excavation (Trial 6) .....	32
5.7	Results: Standard NPA (Mozambique) excavation (Trial 7) .....	34
5.8	Results: Standard Mattock excavation (Trial 8) .....	35
5.9	Results: Prodding (Trial 9) .....	37
6	Conclusions.....	38
6.1	AVS Conclusions from the results .....	38
6.2	AVS Recommendations.....	40
6.2.1	AVS Lessons learned for future trials .....	40
6.3	Conclusions from observer organisations.....	40
6.3.1	BAM conclusions from the results .....	40
6.3.2	BAM Lessons learned for future trials .....	41
6.3.3	QinetiQ conclusions from the results.....	41
6.3.4	QinetiQ recommendations .....	41
	Annex A: References.....	42
	Annex B: Trial records AVS, November 2004.....	44
	Annex C: Debriefing of Deminers and Section-Commanders.....	125
	Annex D: QinetiQ trial report .....	144
	Annex E: BAM trial report.....	152

## Summary

A series of comparative trials of manual demining techniques were undertaken at Moamba in Southern Mozambique, with essential assistance from (UN)ADP. These limited trials pitted varied manual demining techniques against each other in a common environment in order to assess their relative efficiency in terms of speed and safety. Various demining groups were invited to participate, and NPA in Mozambique, NPA in Sri Lanka and ADP Mozambique provided essential manpower, training and monitoring assistance.

To maximise the quantitative output that would be of statistical value, the German institute BAM advised during the planning phase. To maximise the objectivity of the analysis of the results, the British research group QinetiQ, BAM and ADP QA staff assisted with the monitoring of the trials. All, including the deminers themselves, produced analyses of what could be derived from the trials. Some of the results are qualitative, and some quantitative. When all results coincide, the level of confidence in the accuracy of that result is believed to be unusually high.

Eight manual demining techniques were compared in terms of speed, safety to the deminer, safety to the end-user, comfort and confidence. These methods were:

- 1 standard metal-detector use with signal-investigation tools
- 2 standard metal-detector use with magnet attached to signal-investigation tools
- 3 standard metal-detector use with signal-investigation tools and a “magnet Brush-rake”
- 4 area-excitation using an enxada (mattock) and conventional investigation tools
- 5 area-excitation using a conventional garden spade and conventional investigation tools
- 6 area-excitation using an NPA excavator and conventional investigation tools
- 7 area-excitation using a rake-based system (REDS)
- 8 prodding, using standard low-friction prodder and conventional investigation tools

The standard use of metal-detector with magnetic signal-investigation tools was repeated with and without excessive fragmentation in the area, and a separate trial to determine the accuracy of deminer pinpointing was also conducted.

The trial area was set up with identical test lanes from which all undergrowth had been removed. The lanes contained concealed mine surrogates that accurately reflected the size and detector signature (to the Minelab F1A4 that was used) of Type 72 AP blast and GYATA-64 AP blast mines. Randomly placed in a manner that ensured that the deminers did not know how many were in an area, the surrogate mines included a witness plate on the top surface to record damage that occurred during their recovery.

The trials compared entire systems, not just the tool variations. The systems included area-marking and internal QA from the supervisors of the deminers. For all systems, the required clearance depth was the Mozambique National standard of 13cm.

All systems except prodding were effective at locating mines, although some deeply buried mines were missed. In most cases, those missed were Type 72 surrogates buried at 12cm to the top of the mine (about 13cm to the top of the metal insert).

In a heavily fragmented area, the most efficient method of clearance was using a metal-detector and a magnet Brush-rake. The use of signal-investigation tools that included a magnetic attachment was the next fastest. The use of a magnet Brush-rake in areas with cut vegetation or leaf litter might have given an even greater speed advantage.

When a metal-detector was NOT used, the most efficient method of clearance was that involving the use of a conventional garden spade and conventional investigation tools.

The method most likely to involve an accident to the deminer carrying it out was prodding. Prodding at 30° to the ground achieved an average clearance depth of less than 4cm, and all the mine-surrogates that were located during the trial had been damaged by prodding onto their pressure-plates.

After prodding, the method most likely to involve a deminer accident was area-excavation using a mattock (enxada) (this finding coincides with that derived from the available accident records in the DDAS<sup>1</sup>).

The methods most likely to leave mines behind were area-excavation in which the required clearance depth was not maintained, and excessive speed meaning that deep signals were missed during metal-detector based clearance.

A post-trial evaluation of the methods and approaches employed during the trials determined that the variations between different demining teams meant that the different tools and methods were not the only variables affecting the results. An expanded repetition of the trials that allowed each separate demining team (deminers and supervisor) to use each method in turn would provide a more direct comparison, and so yield more quantitatively compelling results.

---

<sup>1</sup> UNMAS/GICHD Database of Demining Accidents, DDAS, 2005.

## 1 Foreword

This report documents a part of the AVS contribution to the GICHD study of Manual Mine Clearance. The scope of the overall study has been broad, and its execution has involved GICHD staff and selected external specialists contracted to undertake discrete aspects of the study. As such, this report should be viewed in conjunction with all related AVS field study reports, and with the final GICHD report drawn together by the study leader.



## 2 Introduction

Following AVS field studies that identified and confirmed common techniques, tool and processes employed in manual demining, formal field trials of a variety of manual demining techniques were devised. Partners with specialist skills in research and in statistical analysis were invited to take part in the trials, and the trials were conducted with assistance from three field demining groups in Mozambique during October and November 2004. The leading field partner was ADP Mozambique, which provided monitoring and evaluation staff as well as deminers, equipment and a wide variety of other resources.

The purpose of the evaluative trials was to compare the relative efficiency of varied manual demining techniques. The trials were conducted at a training base belonging to ADP and situated in rural Mozambique. The trial area was prepared in a manner designed to limit variables and ensure that each method under trial was assessed in a context and under circumstances that were as similar as possible, and which closely reflected demining reality in that region.

Quantitative and qualitative evaluation of the results was conducted by QinetiQ UK, BAM Germany, the ADP deminers and the author of this report. Where the varied conclusions derived from the trials coincide, it is felt that the variety of skills and experience held by those assessing the results adds compelling weight to the findings.

The evaluation reports provided by QinetiQ and BAM are given in Annex D and E of this report. The results of interviews with the deminers are also reproduced in an Annex.

## 3 Comparative trials in Mozambique

Trials of manual demining methods took place in Moamba, Mozambique during October and November 2004.

Of those trial categories listed under IMAS 03.40, these trials are best described as “concept and technology demonstrator trials”, although unanticipated outcomes gave them something in common with “demonstration” and “acceptance” trials.

The most common system of manual-demining - using a metal detector and signal-investigation tools - was compared with selected other manual demining techniques involving a variety of tools.

The organiser and supervisor of the trial was Andy Smith, acting for GICHD. The NMAA in Mozambique (IND) was invited to attend. The main partner and trial facilitator was ADP in Mozambique. While the responsibility for the design and conduct of the trials rests with Andy Smith, he acknowledges essential support and input in trial design from BAM, and in the conduct of the trials from ADP, QinetiQ and BAM.

### **3.1 Aims**

The principal purpose of the trials was to provide quantitative and qualitative data allowing a comparative assessment of the “efficiency of selected manual demining systems. An informed qualitative overview would then be applied to the results.

“Efficiency” was to be measured in terms of speed, the location of targets within a predefined depth, the safety of the deminer while conducting the varied drills, the safety of the end-user of the land, deminer comfort and deminer confidence.

The trial of complete manual demining “systems”, including familiar PPE, marking, tools and QA checks, was intended to limit the number of “unfamiliar” variables that the deminers had to deal with, and so make it more likely that the variation in results was a direct consequence of the particular variation under assessment.

#### **3.1.1 Limitations to aims**

It was recognised that the trials could only be conducted in one place at one time, and with a small set of experienced deminers, so the “findings” could not always be broadly applicable.

There were strict time and cost constraints on the trials, with a non-negotiable finish date. The risk of inclement weather was high, so whenever possible, trials were conducted in parallel to make maximum use of fine-weather days.

The number of experienced monitors was limited, and very little time was available for instruction and practice. The need to use inexperienced monitors meant that the quality and quantity of information recorded for each trial was expected to vary. The core data requirements were deliberately limited in order to ensure that the essential data was successfully gathered.

The combined constraints meant that it was not realistic to aim to “prove” anything definitively. The objective was to achieve consensus over conclusions that, in context, could be compelling.

### **3.2 Trial conditions**

The trials were conducted in selected parts of the ADP test area in Moamba, near Maputo in Southern Mozambique. All trial areas were prepared in an “identical” manner, although the position of the concealed surrogate-mines varied (the positions were randomised).

All trials were conducted in areas where the vegetation had been cut and lanes marked. Surrogate-mines and typical minefield metal fragmentation had been concealed in mapped positions inside the lanes, with the position of the targets determined by the statistical specialists at BAM with a view to leaving the deminers uncertain about the number, depth and position of surrogates that were placed in any one lane.

The Ground Reference Height (GRH) throughout the trial area was measured by BAM, and reported to have been less than 10cm throughout the area, with no significant variations.

Surrogate-mines were prepared with a metal content that made the Minelab F1A4 metal-detector signal with the same strength at the same depth as when a real mine was used. The surrogates were concealed at two depths, 1cm and 12cm to the top of the target.

Experienced deminers worked to approximately their normal work/rest routines and under the supervision of a “familiar” Section Commander. Their actions were recorded by a Trial Monitor who was constantly present. The Trial Monitors observed and recorded events without interfering with the work in progress.

During the trials, the clearance depth required was Mozambique's minimum standard of 13cm to the top of the mine/device.

Each test was conducted over an area comprising four 5 metre long and one metre wide lanes. The lanes were separated. This kept the marking requirement identical and meant that any targets near the side of the lane had to be found during that lane's clearance, not the next. It also allowed full observation without physical interference.

Two test areas (each of two lanes) were used for each trial, which was conducted by two “one-man-drill” deminers and a single field supervisor (Section Commander) controlling both deminers and carrying out routine internal QA checks on their areas.

### 3.2.1 Total trial area

It was decided to use a “herringbone” design for the trial area so that deminers engaged in the same trial could work close to each other while having their backs to each other and so being unaffected by the other’s progress.

Two strips 120 metres long and seven metres wide were prepared. The area between these strips was 20 metres wide. Inside each of the strips, 18 five metre long lanes were measured and marked out, resulting in a total of 36 separate five metre long lanes.



In each strip, the lanes were grouped in pairs with a metre separating the pair, and five metres between it and the next pair [in one case this was varied to avoid an animal path].

One deminer used a pair of 5 metre lanes in each Trial. The second deminer in that Trial used the pair of lanes opposite him in the “herringbone”. One Section Commander oversaw the work of both deminers, much as he would have in a live area. One Trial Monitor could then record the necessary data from both deminers if required, although there was a Monitor for each deminer during almost all of the trials.

### 3.3 Trial duration

All trials (except 9) used two deminers and a supervisor for up to three days or ten metres cleared, whichever was sooner. This meant that there were time constraints as well as an ultimate area constraint of 20m per trial.

The total time period for setting up, training, conducting and closing down the trials was 37 calendar days. The trials themselves were conducted over 15 days (three working weeks).

### 3.4 Targets

Surrogate mines of the right size and colour were designed and made. The numbers were 75 GYATA-64 and 75 Type 72 AP blast mines. These mine-types were selected because they represented a familiar threat to the deminers taking part in the trials. Their preparation and placement only took place in the week before the trials started. Vertical holes were made for placement and water was used during the infill to help the ground settle and disturbed grasses to root. The extreme dryness of the ground led to the rapid spread of the water and helped to effectively conceal the position of the surrogate mines so that the deminers proved unable to see or predict their position, even while digging towards them from the side.



The picture on the right shows how the depths were measured and all surrogate mines placed “level” horizontally.

Each surrogate mine included a “witness-plate” achieved by applying a thick latex (rubber) with a matt varnish overlay to the top of the surrogate. If struck from above, the varnish cracked as the latex flexed. When struck with enough force, the latex was cut and when the tool was withdrawn, the latex “self-sealed” to preserve the evidence of the impact. This worked very well.

The picture on the right shows GYATA-64 surrogates being prepared. The white latex dried clear.



The selection of a metal content for the mines followed a pattern devised by Dieter Guelle in previous detector-performance trials. The Minelab F1A4 detector was used with real mines in the same test area, and a metal insert that gave a similar signal at the required depths was selected for insertion inside the surrogate mines.

The surrogates were not accurate replicas, but they looked convincing, and were all identical, so were constant throughout the trials.

In addition to target mines, approximately identical collections of scrap fragments (from local minefields) were placed for those trials where metal-detector use was being compared with area-excavation. Fragments were positioned flush with surface, and at 1 cm and 2cm depths. The proportion of ferrous to non-ferrous fragments was 30:1, so exceeding the proportion found in the local mined areas (50:1).

The picture on the right shows three approximately identical collections of mined-area fragmentation, including bullets, barbed wire and typical mined-area fragmentation for that region. (Most fragments were from OZM series bounding fragmentation mines.)



### 3.5 Recording data

During clearance, data was recorded for each trial by a Trial Monitor using a pre-agreed recording format.



Ambient weather conditions, speed of coverage, thoroughness of clearance, depth of excavation, damage to targets, and placed-metal removed, were all recorded. Provision was also made to record unexpected sub-surface obstructions (such as old roots or rocks) that took extra time to negotiate, but these were not encountered. More subjectively, the opinions of those involved was canvassed in terms of their confidence in the method and their comfort when carrying out the required procedures.

When a surrogate mine was located, its position was recorded by the Trial Monitor who then removed the device, taking care not to touch it on the top surface. The discovered devices were placed at the far end of the lane where they remained until the day's work was over. Apparent tool impacts were recorded by the Trial Monitor, and later checked by removing the latex witness-plate and examining the top of the surrogates (this was done to all surrogates regardless of whether an impact was apparent).

The damage shown to the top of a GYATA surrogate (on the right) was not visible before the latex was peeled away.



All trials using metal-detectors had one or more buckets in which to place the metal scrap located. The total amount of recovered scrap metal was recorded. In trials where magnets were used, each deminer had a second bucket in which to place metal recovered with the aid of the magnets. The number of fragments found with a magnet was also recorded.



After trials using area excavation methods, random depth-achievement checks were made. No depth checks were made during work or prior to the end of the trial in that area.



### 3.6 Trial Monitor's duties

These were divided amongst Monitors and, for example, all photographs were often taken by one monitor. No trial could start without a Monitor present for that trial.

What follows were the general duties. Other requirements were added for specific trials.



#### At the start of each trial day

(before deminers entered the trial area):

1. Placing long tape measures between the lanes to be used and securing them with wire hoops.
2. The tape measures were used by the Trial Monitors to record the position or events when they occurred. All measurements were made from the White Metre-Stick (base-stick) and from the right hand side of the lane (as seen by the deminer). The monitor was NOT permitted to use a tape measure inside the lane or disturb the deminer's work in any way. So all measurements made while the deminer was working were made remotely, (by reference to the fixed tape-measure) and so were approximate.

#### At the end of each trial day:

1. Removing the long tape measure and wire hoops.
2. Accurately recording the finish position for the day (from the White metre-stick [Base-stick]).
3. Deminers and Platoon Commanders were NEVER told anything about the trial's progress.
4. Fragments located were counted (when a metal detector was used).
5. The mines located during that trial period were recorded.
6. The targets that had been recovered were photographed. For the trials involving the use of a metal detector, the metal fragments found must also be photographed. The Trial marker sign was included in the photograph so that it was easy to identify later.

#### During a trial period the Trial Monitor:

1. Was not permitted to speak to the deminer or his Platoon Commander.
2. Had to record the time at which each work period started and ended accurately.
3. Had to record the approximate position of each surrogate mine located.
4. Had to remove each surrogate mine located without damaging or touching the top of the device. Had to record an estimate of the time it took them to remove the mine.
5. Had to record any underground roots, rocks or other things that slowed down the deminer's progress, writing down the time that the problem started and ended and describing what the problem was.
6. Had to record the number of buckets of water used (if any).
7. Had to note the time at which all events occurred.

#### After each Trial has been completed (and deminers had left the area):

- a) When a trial involved excavation, the Trial Monitor had to check that the depth required (13cm) has been consistently achieved in both of the five metre long lanes. The positions of the excavations and the depths discovered had to be accurately recorded. The deminers were NOT told the results before the end of the Trials.
- b) The Trial Monitor had to remove any surrogate mines still in the ground and make good the holes so that it is not obvious that anything has been removed (it was permitted for this to be left until the end of the trials or until convenient for internal training).

## 4 Manual demining systems under assessment

Although these trials involved an assessment of the difference that it made to use a different technique in the same area, the trials were actually of complete systems, not just the tools involved. The system included the field supervision and internal QA method, without which the deminers we were using would not have classed an area as having been “cleared”.

### 4.1 Standard method (Trial 1)

Minelab GC detectors and ADP investigation tools were used to clear the trial areas by two ADP deminers under the supervision of a Section Commander. The ADP long tools were used to ensure that all tools used by ADP were identical, apart from those deliberate additions under evaluation. This activity was the main “control” against which all others were to be measured. (The “prodding only” method, see Section 4.9, provided a second “control”).

**Expectations:** the level of metal contamination was expected to make this intolerably slow - and the resulting frustrating was expected to mean that it might not be thorough.

**Quantitative records were made of:** time; area; ambient conditions; concealed mines located; damage to mines located; fragments located; unusual sub-surface features that affected speed of advance. The method of internal QA/C was also recorded.

**Qualitative assessments were made of:** safety of method; comfort of tools used; user confidence in safety and thoroughness; confidence in internal QA/C; potential for external Post-clearance QA/C.

**Trial area used:** each trial area comprised, in total, four x five metre long, one metre wide lanes. Both deminers cleared two five metre long lanes. Each pair of 5 metre lanes had eight concealed mines, GYATA-64 and Type-72 surrogates. Each 5 metre lanes was sown with 30 selected (near identical) fragments as well as the target surrogate-mines.

**Personnel:** The trial was conducted by ADP TEAM 1 using their normal Minelab F1A4 detectors, long handtools without magnets, buckets for scrap metal and water, the standard ADP PPE and ADP marking systems.

The two deminers engaged in the trial were overseen by an ADP Section Commander with responsibility for conducting internal QA on their work.

The trial was overseen by two independent monitors, one recording each deminer’s work.



## 4.2 Standard plus magnet-clip on tool (Trial 2)

Minelab GC detectors and ADP investigation tools were used to clear the trial areas by two ADP deminers under the supervision of a Section Commander. The ADP long tools were used to ensure that all tools used by ADP were identical, (apart from those deliberate additions under evaluation). The trowel was adapted to reflect CMAC Cambodia's tool with a magnet along one edge.



When a signal was encountered, the magnet was used (without touching the ground) to try to lift any scrap that was present (as shown in the picture on the right).

If that failed, the unmagnetised edge of the trowel was used to lightly scrape the ground surface and the spoil rolled over the magnetic edge and off the trowel. When that failed, standard signal-investigation procedures were followed and the spoil rolled over the trowel as the deminers worked (as shown in the picture on the right).



**Expectations:** This was expected to show a marked increase in speed over Method 1, and possibly an increase in thoroughness.

**Quantitative records were made of:** time; area; ambient conditions; concealed mines located; damage to mines located; fragments located by magnet and otherwise; unusual sub-surface features that affected speed of advance. The internal QA/C work was also recorded.

**Qualitative assessments were made of:** safety of method; comfort of tools used; user confidence in safety and thoroughness; confidence in internal QA/C; potential for external Post-clearance QA/C.

**Trial area used:** Trial areas comprising in total four x five metre long, one metre wide lanes. Both deminers cleared two five metre long lanes. Each pair of 5 metre lanes had eight concealed mines, GYATA-64 and Type-72 surrogates. Every 5 metre lane was sown with 30 selected (near identical) fragments as well as the target surrogate-mines.

**Personnel:** The trial was conducted by ADP TEAM 2 using their normal Minelab F1A4 detectors, long handtools with magnets, buckets for scrap metal and water, the standard ADP PPE and standard ADP marking systems.

The two deminers engaged in the trial were overseen by an ADP Section Commander with responsibility for conducting internal QA on their work.

The trial was overseen by two independent monitors, one observing each deminer.

**Note:** The use of a new tool required a period of training/introduction to the magnet method.

### 4.3 Standard plus MBR (Magnet Brush-rake) – Trial 3

Minelab GC detectors were used along with a modified magnet Brush-rake (a two- metre long tool) to try to clear the trial areas by two ADP deminers under the supervision of a Section Leader. When there was a detector signal, the ground area was swept with the Brushrake and the attached magnet picked up ferrous fragments. The Brushrake magnet was used along with the detector and other long ADP excavation tools (that had no magnets attached).



**Expectations:** used appropriately (depending on the ground), the rake was expected to pick up at least four of the fragments per square metre, and possibly to expose at least some target mines. It was anticipated that it might be very much quicker than methods 1 and 2.

**Quantitative records were made of:** time; area; ambient conditions; concealed mines located; damage to mines located; fragments located by magnet and otherwise; unusual sub-surface features that affected speed of advance. The method of internal QA/C was also recorded.

**Qualitative assessments were made of:** safety of method; comfort of tools used; user confidence in safety and thoroughness; confidence in internal QA/C; potential for external Post-clearance QA/C.

**Trial area used:** Trial areas comprising in total four x five metre long, one metre wide lanes. Both deminers cleared two five metre long lanes. Each pair of 5 metre lanes had eight concealed mines, GYATA-64 and Type-72 surrogates. Every 5 metre lane was sown with 30 selected (near identical) fragments as well as the target surrogate-mines.

**Personnel:** The trial was conducted by ADP TEAM 2 using their normal Minelab F1A4 detectors, magnet Brush-rakes, long handtools, buckets for scrap metal and water, the standard ADP PPE and standard ADP marking systems.

The two deminers engaged in the trial were overseen by an ADP Section Commander with responsibility for conducting internal QA on their work.

The trial was overseen by two independent monitors, one observing each deminer.

**Note:** The use of a new tool required a period of training/introduction to the magnet method.

#### 4.4 Detector in low-fragment area (Trial 4)

The Minelab GC detectors alone were used – and target indicators placed without investigation by two ADP deminers under the supervision of a Section Leader. The deminers then changed their working areas, the position of markers was recorded and the markers removed, then the detection and pinpointing exercise was repeated including the investigation of the signals. This trial was intended to check the accuracy and replicability of detector pinpointing. Fragments were not placed in this area.

**Expectations:** some variation between signal placement and target position was anticipated.

**Quantitative records were made of:** time; area; ambient conditions; concealed mines located; damage to mines located; position of all markers placed; position of actual targets relative to marker-placement; unusual sub-surface features that affected speed of advance. The method of internal QA/C was also recorded.



**Qualitative assessment of:** reasons for any discrepancy between marker and target.

**Trial area used:** Trial areas comprising in total four x five metre long, one metre wide lanes. Both deminers cleared two five metre long lanes, then changed to work on their partner's area. Each pair of 5 metre lanes had eight concealed mines, GYATA-64 and Type-72 surrogates.

**Personnel:** The trial was conducted by ADP TEAM 1 using their normal Minelab F1A4 detectors, long handtools with magnets, buckets for scrap metal and water, the standard ADP PPE and standard ADP marking systems.

The two deminers engaged in the trial were overseen by an ADP Section Commander with responsibility for conducting internal QA on their work.

The trial was overseen by two independent monitors, one observing each deminer.

This trial was adjusted and extended as it ran, so increasing confidence in the result, but taking longer than planned.

##### 4.4.1 The “reliability” part of Trial 4

Trial 4 consisted of two parts. The first part was a “detection reliability” trial intended to add value to earlier trials carried out by BAM (and not part of this trial series).

Detection reliability tests are described in the CEN Workshop Agreement CWA 14747:2003. (available at <http://humanitarian-security.jrc.it/demining/cw07/>). To conduct the reliability test, targets were placed in metal-free lanes at positions not known to the detector users. While using the metal-detector, the operators placed indicators where they believed a target to be centred. The position of the markers was recorded after the deminer had finished.

**Expectations:** following earlier trials with controversial results, it had been argued that the results of a full demining process (including investigation of each signal) would be higher than the results of a reliability test. It had also been argued that the accuracy of pinpointing was not critical to the successful location of a target, because having found a signal a deminer would be bound to locate the source, correcting his pinpointing as he investigated the signal.

Each deminer made a pass over two lanes leaving markers on the positions of indications. Position of these markers were measured and compared with actual positions of the targets. A target was considered to have been detected when a marker was placed within a prescribed radius (“halo”) around the true target location. The halo radius of the GYATA-64 surrogate was 15cm and of the Type-72 surrogate 10cm.

After measuring the position of the markers, the Section Commander checked the deminer's indications, removing, repositioning and adding markers as he saw fit. The position of markers was then recorded again. The markers were removed and a second deminer then cleared the area in a conventional manner, investigating each signal.

#### 4.5 The REDS rake system (Trial 5)

The Rake Excavation and Detection System (REDS) was used to clear the trial area by two ADP deminers under the supervision of a Section Leader. The method was taught by an NPA trainer who came from Sri Lanka for the purpose. REDS is an NPA system of excavation that is ideal on soft ground, but is sometimes used on very hard ground. Two ADP deminers worked under the supervision of a Section Leader.

The pictures on the right shows the heads of the two rakes used: - a Brush-rake and a two-tined Harrow-rake.



**Expectations:** the method was expected to be intolerably slow when compared with others, but to be exceptionally thorough.



**Quantitative records were made of:** time; area; ambient conditions; concealed mines located; damage to mines located; unusual sub-surface features that affected speed of advance. The method of internal QA/C was also recorded.

**Qualitative assessments were made of:** safety of method; comfort of tools used; user confidence in safety and thoroughness; confidence in internal QA/C; potential for external Post-clearance QA/C.

**Trial area used:** Trial areas comprising in total four x five metre long, one metre wide lanes. Both deminers cleared two five metre long lanes. Each pair of 5 metre lanes had eight concealed mines, GYATA-64 and Type-72 surrogates.



**Personnel:** The trial was conducted by ADP TEAM 4 [a combination selected from all the ADP personnel by the NPA trainer in the REDS method] using the REDS Brush- and Harrow- rakes, buckets for water, the standard ADP PPE and the REDS marking systems.

The two deminers engaged in the trial were overseen by an ADP Section Commander with responsibility for conducting internal QA on their work.

The trial was overseen by two independent monitors, one observing each deminer.

**Note:** The use of new tools required a period of training/introduction to the REDS system. The availability of the REDS trainer was a constraint on the timing of the trial.

#### 4.6 Standard ADP spade excavation (Trial 6)

The ADP excavation only system was used to try to clear the trial areas by two ADP deminers under the supervision of an ADP Section Leader. The ADP excavation method involved the use of prodders and a conventional garden spade.

**Expectations:** the method was expected to be thorough, but slow. It was expected that the depth of clearance might vary.

**Quantitative records were made of:** time; area; ambient conditions; concealed mines located; damage to mines located; unusual sub-surface features that affected speed of advance. The method of internal QA/C was also recorded.

**Qualitative assessments were made of:** safety of method; comfort of tools used; user confidence in safety and thoroughness; confidence in internal QA/C; potential for external Post-clearance QA/C.



**Trial area used:** Trial areas comprising in total four x five metre long, one metre wide lanes were used. Both deminers cleared two five metre long lanes. Each pair of 5 metre lanes had eight concealed mines, GYATA-64 and Type-72 surrogates.

**Personnel:** The trial was conducted by ADP TEAM 1 using their normal long handtools and a garden spade, buckets for water, the standard ADP PPE and standard ADP marking systems.

The two deminers engaged in the trial were overseen by an ADP Section Commander with responsibility for conducting internal QA on their work.

The trial was overseen by two independent monitors, one observing each deminer.

**Note:** The ADP deminers had not actually used the spade method since their training, so refresher training was carried out before the trial. The picture on the right was taken during refresher training.



#### 4.7 Standard NPA (Mozambique) excavation (Trial 7)

The NPA Mozambique excavation system was used to clear the trial areas by two NPA deminers under the supervision of an NPA Section Leader. NPA Mozambique sent two deminers, and a Section Commander/QA person to take part in the trials – using the complete system (including marking) which they were accustomed to.

The picture on the upper right shows the NPA deminer wearing their standard PPE as he worked.



The picture lower right shows the NPA marking system, which varied significantly from the ADP system but did not take significantly more time to use.



**Expectations:** the method was expected to be thorough, but slow. It was anticipated that the clearance depth might vary.

**Quantitative records were made of:** time; area; ambient conditions; concealed mines located; damage to mines located; unusual sub-surface features that affected speed of advance. The method of internal QA/C was also recorded.

**Qualitative assessments were made of:** safety of method; comfort of tools used; user confidence in safety and thoroughness; confidence in internal QA/C; potential for external Post-clearance QA/C.

**Trial area used:** Trial areas comprising in total four x five metre long, one metre wide lanes were used. Both deminers cleared two five metre long lanes. Each pair of 5 metre lanes had eight concealed mines, GYATA-64 and Type-72 surrogates.

**Personnel:** The trial was conducted by NPA TEAM 1 using their normal handtools and a short excavation tool, buckets for water, the standard NPA PPE and standard NPA marking systems.

The two deminers engaged in the trial were overseen by an NPA Section Commander with responsibility for conducting internal QA on their work.

The trial was overseen by two independent monitors, one observing each deminer.

#### 4.8 Standard Mattock excavation (Trial 8)

The Enxada (Mattock) system was used to clear the trial areas by two ADP deminers under the supervision of a Section Leader. The Enxada excavation method involved the use of prodders and an Enxada (mattock). Mattocks of various sizes were sourced and the size most closely reflecting the type used in Mozambique was used.



**Expectations:** the method was expected to be thorough, and relatively fast. It was anticipated that depth might vary and mines might be struck on the top.

**Quantitative records were made of:** time; area; ambient conditions; concealed mines located; damage to mines located; unusual sub-surface features that affected speed of advance. The method of internal QA/C was also recorded.

**Qualitative assessments were made of:** safety of method; comfort of tools used; user confidence in safety and thoroughness; confidence in internal QA/C; potential for external Post-clearance QA/C.

**Trial area used:** Trial areas comprising in total four x five metre long, one metre wide lanes were used. Both deminers cleared two five metre long lanes. Each pair of 5 metre lanes had eight concealed mines, GYATA-64 and Type-72 surrogates.

**Personnel:** The trial was conducted by ADP TEAM 2 using their normal handtools and an enxada, buckets for water, the standard ADP PPE and standard ADP marking systems.

The two deminers engaged in the trial were overseen by an ADP Section Commander with responsibility for conducting internal QA on their work.

The trial was overseen by two independent monitors, one observing each deminer.

**Note:** ADP deminers had not used this tool before. Two ADP deminers and a Section Leader were trained in the Mattock system by one of the ADP trainers who had formerly worked as a field supervisor with a group that used Mattocks.

#### 4.9 Prodding (Trial 9)

In a second "control test", ADP (low-friction) prodders were used to determine the actual depth that could be prodded in the conditions prevalent at the trial site. Two deminers worked on separate areas of a single square metre in which targets had been placed at depths straddling what it was apparently possible to prod to in that ground.

The picture on the right shows the low-friction prodders used during the trial (the same tools are standard UN ADP issue).



**Expectations:** It was anticipated that it would be impossible to achieve a 10cm depth in that ground.

**Quantitative records were made of:** depth of prodding; angle of prodding; concealed mines located by type of prodder; damage to mines; depth beyond which targets were not located.

**Subjective assessment of:** safety of method; comfort of tool use; user confidence in safety and thoroughness; confidence in internal QA/C; potential for external Post-clearance QA/C.

**Personnel:** The trial was conducted by ADP TEAM 1 using their normal long handtools, the standard ADP PPE and standard ADP marking systems. Water was not used.

The two deminers engaged in the trial were overseen by an ADP Section Commander with responsibility for conducting internal QA on their work.

The trial was overseen by two independent monitors, one observing each deminer.

The picture shows the deminer, Section Commander and Monitor. PPE was not worn during this trial because it was not intended to replicate reality in the same way as the others did.



**Note:** This was a "control" trial and restricted to a maximum of one day. Some training was required because the ADP deminers do not normally use prodding for area-clearance (they had been told to use it for emergency evacuation only).

## 5 Results

What follows are the results of the trials, summarised from the records you will find in annexes to this report.

The full results of Trial 4 cannot be compared to those from other trials. The trial was conducted with the primary aim of determining how accurately the deminers could pinpoint a metal-signature using their Minelab detectors. Those results that can be usefully placed alongside those from the other trials are shown below.

Trial 9 cannot be directly compared with the results from the other trials. It was conducted in order to confirm the limitation of the method, which had been shown (empirically) to be incapable of achieving clearance to the required depth.

This Section begins with a few general charts to give an overview, followed by the detailed results for each trial in turn.

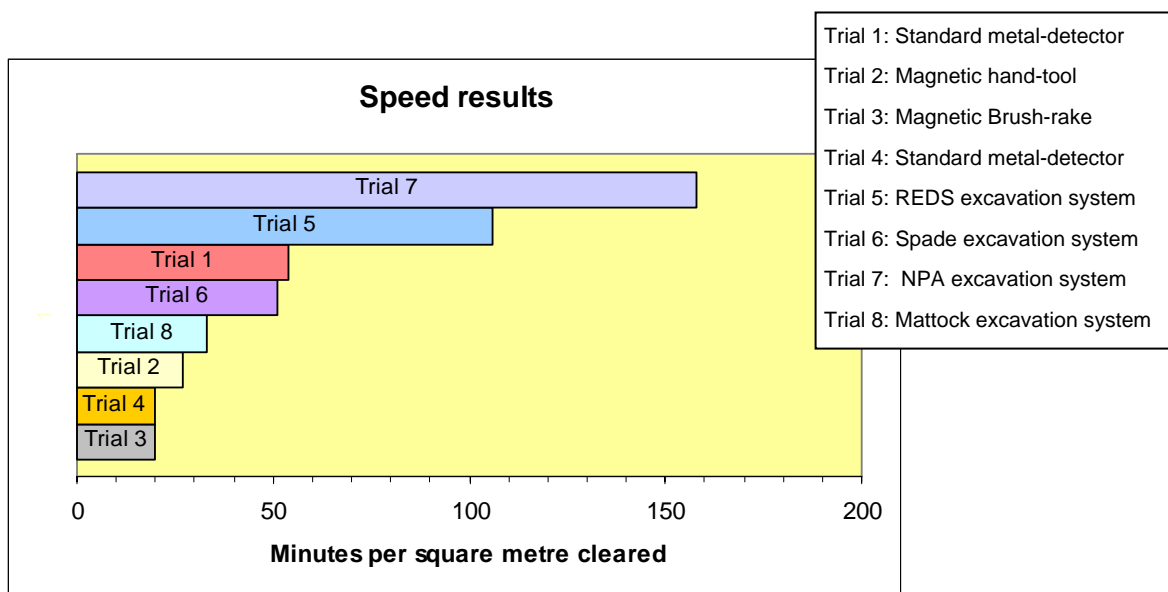

The chart above shows the relative speeds of the methods under trial (in minutes taken to clear each square metre). The fastest were Trials 3 and 4. Trial 3 was a heavily fragmented area cleared using a magnetic Brush-rake and a metal-detector. Trial 4 was an area with very few fragments (not deliberately placed) cleared with a magnetic hand-tool and a metal-detector. The implication is that the use of the magnetic Brush-rake negated the adverse effect on speed normally associated with heavy fragmentation.

In Trial 3, the fragmentation level was the same as in Trial 1 (where magnets were not used). The metal-detector signal density in Trial 1 and 3 averaged more than 7 per square metre. In Trial 4, the nominal density was 2 per square metre. (These averages include the mine surrogates placed in the area). By using the magnetic Brush-rake, a high-fragmentation area like Trial 1 was reduced to a low fragmentation area like trial 4.

The fastest excavation method, Trial 8 used a mattock and took a little more than half the time that it took to clear the same area with a metal-detector (and no magnet) but almost twice the time that it took to clear the area with a metal-detector and a magnet. The mattock excavation method involved the use of a tool that led to very poor deminer safety results, which the deminers believed could not be improved because the tool itself was inappropriate.

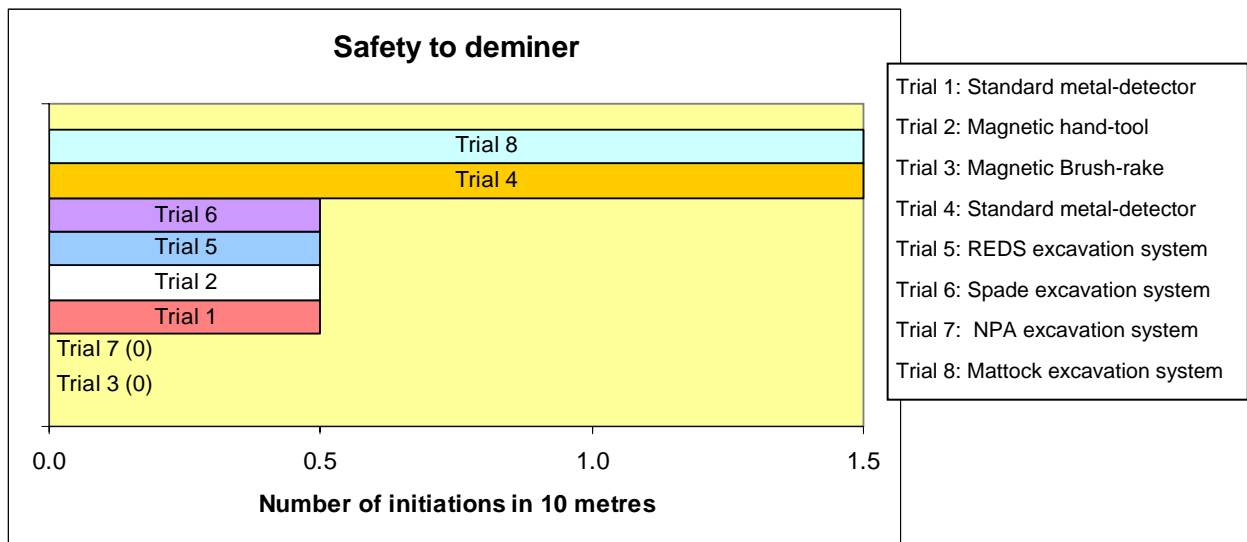

The chart above shows the relative safety to the deminer when he was using the manual demining methods under comparison. An “initiation” was considered to have occurred when there was damage to the top of the mine-surrogates that was extensive enough to make an initiation probable. The number of “initiations” is surprising and does not match the accident record for the demining groups involved in the trials. That discrepancy may be best explained by the fact that the deminers knew there was no real risk of injury inside the trial area.

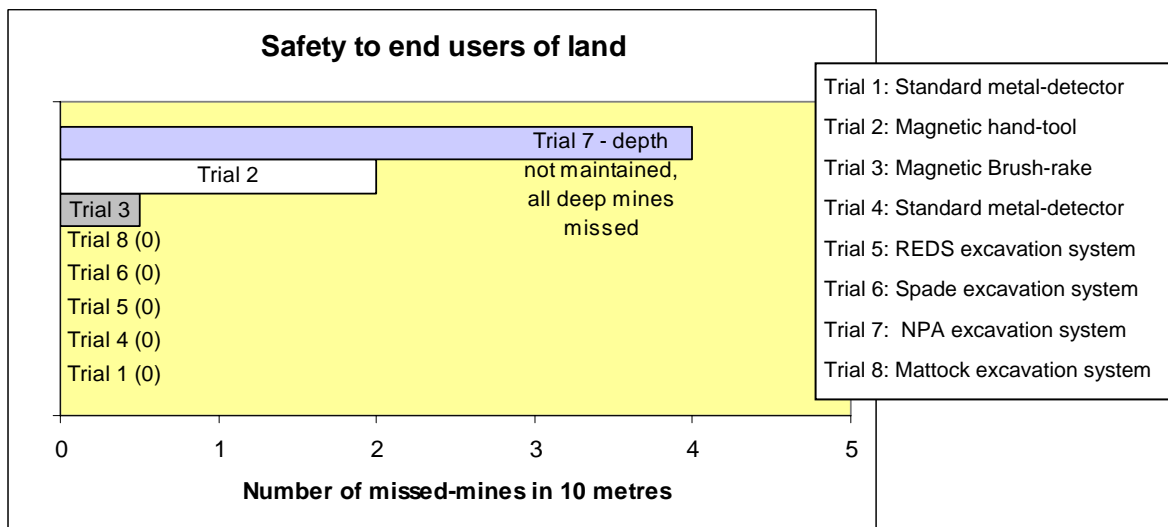

The chart above shows the number of mine-surrogates that were missed when using the various methods. The surrogates were of mine-types that were familiar to the deminers but some were buried at unrealistic depths. All except one missed mines were Type 72 AP blast-mine surrogates buried with the top of the mine at 12cm below the surface (a depth far beyond that at which it is “normal” to find these mines). The metal content inside the surrogates was 13 centimetres below the surface, (13cm is the National clearance-depth in Mozambique). The tiny metal signature at that depth sometimes failed to make the detector signal, and was (at least once) ignored as a detector aberration.

While the unstable and inconsistent performance of well-used metal-detectors may explain the deeply buried surrogates missed in Trial 2 and 3, it was the failure of the Section Commander to correct depth errors that was directly responsible for the poor performance in Trial 7.

## 5.1 Results: Standard metal-detector method (Trial 1)

Minelab GC detectors and ADP investigation tools were used to clear the trial areas by two ADP deminers under the supervision of a Section Commander.

***This trial was conducted by ADP Team 1.***

**Expectations:** the level of metal contamination was expected to make this intolerably slow - and the resulting frustrating was expected to mean that it might not be thorough.

**Lanes 1 and 2:** In Lanes 1 and 2, all mines were located, one during the internal QA check.

Ten metres was cleared in 598 minutes, so giving a nominal average rate of advance of 60 minutes per square metre.

One GYATA showed tool marks in several places on the side of the mine. Given the design of the mine, the impacts were not felt likely to have caused an initiation.

When the top of the discovered mines was exposed, there was heavy prodder damage to the top of one Type 72, with wood penetration to approx. 4mm. It was felt likely that this would have caused a real Type 72 mine to have functioned.

**Lanes 3 and 4:** In Lanes 3 and 4, all 8 mines were located by the deminer.

Two 5 metre long lanes were cleared in 474 minutes, so giving a nominal rate of advance of approximately 47 minutes per square metre.

When the top of the discovered mines was exposed, there was no evidence of impact strikes on the top of the mines.

**Best speed results:**

Average speed, in minutes per square metre: 47

Safety to deminers (number of likely initiations): 0

Safety to end user of land (number of missed mines): 0

**Worst speed results:**

Average speed, in minutes per square metre: 60

Safety to deminers (number of likely initiations): 1

Safety to end user of land (number of missed mines): 0

**Average results:**

Average speed, in minutes per square metre: 54

Safety to deminers (number of likely initiations): 0.5

Safety to end user of land (number of missed mines): 0

**Best safety result:** no injury to deminer and no mines left.

**Worst safety result:** one injury to deminer, no mines left.

**QA potential:** internal and external QA/C with metal-detectors was possible.

**Expectations evaluated:** expectations of the results of this trial were broadly met.

**Deminer opinion:** the deminers felt that this method was proven and was safe for both deminers and end-users of the land as long as the detectors were correctly adjusted and working properly. Some concern about the age and condition of the detectors was expressed. Interestingly, the two deminers felt that their performance could have been improved with more training. Neither deminer was totally confident that mines were not left behind (all mines were located).



## 5.2 Results: Standard plus magnet-clip on tool (Trial 2)

Minelab GC detectors and ADP investigation tools were used to clear the trial areas by two ADP deminers under the supervision of a Section Commander. The trowel was adapted with a magnet along one edge (on both sides of the trowel blade). The back of the magnet was passed over the ground without touching to attract surface fragments. Spoil was rolled over the magnet while excavating to extract any ferrous items.



***This trial was conducted by ADP Team 2.***

**Expectations:** This was expected to show a marked increase in speed over Method 1, and possibly an increase in thoroughness.

**Lanes 1 and 2:** Six mines were located by the deminer during this trial. The deminer and his Section Commander (QA) worked for 188 minutes to clear ten metres, so achieving a nominal clearance rate of a metre every 19 minutes.

On removing the witness plate (latex top) of the discovered targets, light corner damage (wood exposed) was found on the top corner of a GYATA and evidence of a lateral strike across the top of one Type 72 was apparent (wood dented, latex torn). Given the method of initiation and the damage, it was felt likely that a real GYATA mine would have been initiated.

Two mines were missed (one GYATA and one Type 72, buried at 12cm to top).

64 fragments were found with a magnet, 6 ferrous fragments were found without the magnet and 2 non ferrous fragments. The total number of fragments were 70. [Two fragments were found outside of the lanes so are discounted.] Total mines found by the deminer were 6, and two were missed (one located by the Section Commander during QA).

The items found, (77), gives an average signal density of 7.7 in each metre over ten metres.



**Lanes 3 and 4:** Five mines were located by the deminer during this trial. A further mine was located by the QA. Ten metres were cleared in 344 minutes, at a nominal average advance of a metre in every 34 minutes.

On removing the latex top of the discovered targets, no tool damage was found on the top of them. Two mines were missed (both Type 72, buried at 12cm to the top).

80 fragments were found, of which one was found by eye and two were non-magnetic. Five fragments were found in advance of the white stick (in Lane 4) so they should be removed from the calculation for the fragment density of the cleared area.

Five mines were located, so there were 80 signals in the ten metres (excluding missed mines), giving an average signal density of 8 per square metre

### **Best speed results:**

Average speed, in minutes per square metre: 19

Manual demining systems – comparative trials: Mozambique 2004.

Safety to deminers (number of likely initiations): 1

Safety to end user of land (number of missed mines): 2

**Worst speed results:**

Average speed, in minutes per square metre: 34

Safety to deminers (number of likely initiations): 0

Safety to end user of land (number of missed mines): 2

**Average results:**

Average speed, in minutes per square metre: 27

Safety to deminers (number of likely initiations): 0.5

Safety to end user of land (number of missed mines): 2

**Best safety result:** no injury to deminer, 2 mines left.

**Worst safety result:** one injury to deminer, 2 mines left.

**QA potential:** internal and external QA/C with metal-detectors was possible.

**Expectations evaluated:** of a marked increase in speed over Method 1 were met, but the decrease in safety was not anticipated, and may have been more the result of deminer attitude than of the method.

**Deminer opinion:** the deminers felt that this method was safe for both deminers and end-users of the land as long as the detectors were correctly adjusted and working properly. They felt that the magnet-trowel led to a significant increase in speed and this would increase safety because the deminer would be less tired by kneeling to make many signal-investigations. No extra training was felt necessary (because the magnet attached to a familiar tool). [The deminers had tried the tool in training sessions before the trials.]

The picture alongside shows a deminer during training as he tips spoil over the magnet to catch any ferrous items in the earth.



### 5.3 Results: Standard plus MBR (Magnet Brush-rake) – Trial 3

Minelab GC detectors were used along with a modified magnet Brush-rake (a 2 metre long tool) to try to clear the trial areas by two ADP deminers under the supervision of a Section Leader. When there was a detector signal, the ground area was swept with the Brush-rake and the attached magnet picked up ferrous fragments. ***This trial was conducted by ADP Team 2.***

The strip of magnets is attached towards the rear of the rake head so that the flexibility of the tines was not changed – as shown in the picture alongside.



**Expectations:** that the magnet Brush-rake would pick up at least four of the fragments per square metre and might expose the shallow surrogates. The method was expected to be potentially quicker than Methods 1 and 2.

**Lanes 1 and 2:** six mines were located by the deminer during this trial. A further mine was located during the integral QA. Ten metres were cleared by deminer and QA in 177 minutes, at a nominal average advance of a metre in every 18 minutes.

The discovery of fragments with or without the magnet was not accurately recorded, and the total number of fragments not counted. The same number of fragments were placed as in lanes 3 and 4, so the record for lane 3 and 4 is copied here: over the ten metres, the average fragment/mine density was 7.4 per square metre.

On removing the latex top of the discovered targets, light prod damage was found on the top of one Type 72 and one GYATA. It is considered unlikely that either would have been initiated without greater pressure.

One mine was missed (Type 72, buried at 12cm). A further Type 72 was only located during the system's QA (this was the mine with light damage on top).

**Lanes 3 and 4:** All 8 mines were located by the deminer during this trial. Ten metres were cleared in 221 minutes, at a nominal average advance of a metre in every 22 minutes. Over the ten metres, the average fragment/mine density was 7.4 per square metre.

88% of the fragments were found using the magnet Brush-rake.

On removing the latex top of the targets, light prod damage (penetrating latex and paint and exposing wood) was found on the top of one GYATA and one TYPE 72. It was not thought likely that the damage would have initiated a real device.



#### **Best speed results:**

Average speed, in minutes per square metre: 18  
Safety to deminers (number of likely initiations): 0  
Safety to end user of land (number of missed mines): 1

#### **Worst speed results:**

Average speed, in minutes per square metre: 22  
Safety to deminers (number of likely initiations): 0  
Safety to end user of land (number of missed mines): 0

**Average results:**

Average speed, in minutes per square metre: 20

Safety to deminers (number of likely initiations): 0

Safety to end user of land (number of missed mines): 0.5

**Best safety result:** no injury to deminer and no mines left.

**Worst safety result:** no injury to deminer, one mine left.

**QA potential:** internal and external QA/C with metal-detectors was possible.

**Expectations evaluated:** the expectation that the magnet Brush-rake would pick up at least four of the fragments per square metre was met. It was not recorded whether the rake actually exposed any of the shallow surrogates. The method was very much quicker than Method 1, and faster than Method 2, as anticipated.

**Deminer opinion:** the deminers disagreed about the safety of the Brush-rake because of uncertainty about detonating mines. They agreed that it made the work faster and was comfortable. Improvements to the tool were suggested, and it was agreed that they would have been better at using it if they had more training/experience. [The deminers had tried the tool in training sessions before the trials, during which they were shown how to use it.] Being issued with both the magnet Brush-rake and the clip-on magnet for a hand tool was considered “ideal”.

The picture on the right shows a deminer cleaning fragments from the magnet on the rake-head.



#### 5.4 Results: Detector in low fragment area (Trial 4)

The Minelab GC detectors were used – and target indicators placed without investigation by two ADP deminers under the supervision of a Section Leader. The position of markers was recorded and the markers removed, then the deminers changed their working areas, and the detection and pinpointing exercise was repeated including the investigation of the signals. The results for the latter part of this trial are included below. No deliberate fragments were placed, so the targets were limited to 8 surrogate mines in each 10 metre area (plus some unplaced fragments).

***This trial was conducted by ADP Team 1.***

The picture on the right shows a deminer who has found a fragment with the magnet on the back of his trowel during this trial.



**Expectations:** some variation between signal placement and target position was expected. Thorough clearance at a speed faster (because of fewer fragments) than Trial 2 was anticipated. Difficulty in accurately measuring a position (to within a few centimetres) was predicted.

**Lanes 1 and 2:** The ten metre area was cleared in 207 minutes, so giving a nominal advance rate of one metre every 21 minutes. All 8 surrogate mines were found, one during the internal QA. 13 fragments were found (12 using a magnet-clip on the trowel), so the signal density was 2.1 indications per square metre. Three surrogate mines were so damaged during investigation that an initiation of a real mine was judged probable.

One of the damaged mines is shown alongside with the latex witness-plate peeled back.



**Lanes 3 and 4:** The ten metre area was cleared and QA checked in 195 minutes, so giving a nominal advance rate of one metre every 19.5 minutes. All 8 surrogate mines were found, one during the integral QA. 15 fragments were found, (10 using a magnet clip on the trowel), so the signal density was 2.3 indications per square metre. Three surrogate mines showed some damage, but none to the extent that an initiation was deemed probable.

#### **Best speed results:**

Average speed, in minutes per square metre: 19.5  
Safety to deminers (number of likely initiations): 0  
Safety to end user of land (number of missed mines): 0

#### **Worst speed results:**

Average speed, in minutes per square metre: 21  
Safety to deminers (number of likely initiations): 3  
Safety to end user of land (number of missed mines): 0

#### **Average speed results:**

Average speed, in minutes per square metre: 20  
Safety to deminers (number of likely initiations): 1.5  
Safety to end user of land (number of missed mines): 0

**Best safety result:** no injury to deminer and no mines left.

**Worst safety result:** deminer injured three times, no mines left.

**QA potential:** internal and external QA/C with metal-detectors was possible.

**Expectations evaluated:** expectations of speed and performance were met. The poor safety may have been because the deminers did not understand the point of the trial and looked on it as “different” from the others.

#### 5.4.1 Results of the “reliability” part of Trial 4

The first part of Trial 4 was a “detection reliability” trial intended to add value to earlier trials carried out by BAM (and not part of this trial series). To conduct the reliability test, targets were placed in lanes at positions not known to the detector users. While using the metal-detector, the operators placed indicators where they believed a target to be centred. The position of the markers was recorded after the deminer had finished.



The picture on the right shows red plastic markers positioned by the deminer to indicate the centre of readings located with the Minelab detector.

**Expectations:** following earlier trials with controversial results, it had been argued that the results of a full process (including investigation of each signal) would be higher than the results of a reliability test. It had also been argued that the accuracy of pinpointing was not critical to the successful location of a target, because having found a signal a deminer would be bound to locate the source, correcting his pinpointing as he investigated the signal.

**Lanes 1-4:** Each deminer made a pass over two lanes leaving markers on the positions of indications. Position of these markers were measured and compared with actual positions of the targets. A target was considered to have been detected when a marker was placed within a prescribed radius (“halo”) around the true target location. The halo radius of the GYATA-64 surrogate was 15cm and of the Type-72 surrogate 10cm.

After measuring the position of the markers, the Section Commander checked the deminer’s indications, removing, repositioning and adding markers as he saw fit. The position of markers was then recorded again. The markers were removed and a second deminer then cleared the area in a conventional manner, investigating each signal.

In the reliability trial, one Type-72 surrogate was missed by the deminer, but found by the Section Commander. Also, one GYATA surrogate was missed by both the deminer and the Section Commander. The Section Commander missed another GYATA. All the mines missed were at 12cm to the top of the device. The GYATA surrogates were marked, but outside the “halo” radius of what was a CEN acceptable detection. In the following full trial, all the GYATAs were located, and all the Type 72s were located (two during the Section Commander’s QA).

**Expectations evaluated:** following earlier trials with controversial results, it had been argued that the results of a full process (including investigation of each signal) would be higher than the results of a reliability test. The result of this trial tends to confirm this, with all targets located during the full trial, including those technically “missed” during the “reliability trial”.

It had also been argued that the placement of a marker inside a “halo” was not critical to successful location of a target, because having found a signal a deminer would be bound to locate the source, whether or not the pin-pointing was accurate. This was also confirmed.

Difficulty in accurately measuring without a fixed base- or side-line may have influenced the result.

## 5.5 Results: The REDS rake system (Trial 5)

The Rake Excavation and Detection System (REDS) was used to clear the trial area by two ADP deminers under the supervision of a Section Leader. REDS is a rake-based excavation system using two rakes, a Harrow-rake and a Brush-rake. The two are used to excavate an area in a way that sieves the ground to the required depth.

**This trial was conducted by ADP Team 4** (comprising selected members of Teams 1+2).

**Expectations:** the method was expected to be intolerably slow when compared with others, but to be exceptionally thorough.

**Lanes 1 and 2:** The deminer cleared 5.12 square metres in a nominal 630 minutes, so achieving an advance of a metre in every 123 minutes. In fact, the lane width (to the bottom of the side trenches) was a measured 12cm wider at full clearance depth. This means that the deminer cleared an area 512 x 112cms, or 5.7344 square metres. The clearance rate was then approximately a metre in 110 minutes.

The deminer found all surrogate mines in the area cleared, a total of five. Of these, two were unmarked. Three were found to have light dents in the top when the latex witness-plate was removed. The damage was not thought likely to have caused an initiation.



**Lanes 3 and 4:** The total area cleared was  $1.63 + 4.2 = 5.83$  square metres in a nominal 663 minutes, meaning an advance rate of a metre every 114 minutes. In fact, the lane width (to the bottom of the side trenches) was a measured 12cm wider at full clearance depth. This means that the deminer cleared an area 583 x 112cms, or 6.5 square metres. The clearance rate was then approximately a metre every 102 minutes.

The deminer(s) found all surrogate mines in the cleared area, a total of 3. Two were undamaged. One surrogate was damaged in a way that was deemed very likely to have caused an initiation. The damaged mine is shown in the picture on the right. A corner of wood has been broken away.



### Best speed results:

Average speed, in minutes per square metre: 102  
Safety to deminers (number of likely initiations): 1  
Safety to end user of land (number of missed mines): 0

### Worst speed results:

Average speed, in minutes per square metre: 110  
Safety to deminers (number of likely initiations): 0  
Safety to end user of land (number of missed mines): 0

### Average speed results:

Average speed, in minutes per square metre: 106  
Safety to deminers (number of likely initiations): 0.5  
Safety to end user of land (number of missed mines): 0

**Best safety result:** no injury to deminer and no mines left.

**Worst safety result:** one deminer injury, no mines left.

**QA potential:** internal QA/C using side-trenches to ensure depth maintenance was effective. Potential for external QA in some soils because of looseness of worked depth also possible (not possible when compacted during work).

**Expectations evaluated:** the expectations regarding speed and thoroughness were met.

**Deminer opinion:** the deminers disagreed with their Section Commander about the safety of the REDS system because of uncertainty about detonating mines with the heavier Harrow-rake. They all agreed that the method was thorough and could not leave mines behind. Concerns about tripwires were also expressed. Improvements to the Harrow rake were suggested, and it was agreed that they would have been better at using it if they had more training/experience. [The deminers had tried the system in training sessions before the trials.] The use of water on hard ground was considered essential, ideally on the day before the method was used.

The picture alongside shows a deminer with the Brush-rake. The side trenches of his lane (that provide a guarantee of his having maintained his excavation depth) are clearly visible.



## 5.6 Results: Standard ADP spade excavation (Trial 6)

The ADP excavation only system was used to clear the trial areas by two ADP deminers under the supervision of an ADP Section Leader. The ADP excavation method involved the use of prodders and a conventional garden spade.



**Expectations:** the method was expected to be thorough, but slow. It was expected that the depth of clearance might vary.

**Lanes 1 and 2:** All eight target mines were discovered by the deminer. Four had no damage. Two showed signs of having been struck on the side. Two had been struck on the top edge by the spade. One top damaged mine was a Type 72 surrogate. The pressure plate of the Type 72 does not extend to the edge of the mine, and is not easy to depress on the sides, so it was considered unlikely that the mine would have functioned. The GYATA surrogate was deemed likely to have initiated if struck in the way recorded.

The deminer worked a nominal 494 minutes in the 10 metre area (including the extra square metre start “base-trenches” that are part of this method). The nominal advance was a metre every 49 minutes.

[This could be adjusted to subtract the time making the start trenches. -25 minutes for trench 1. -28 minutes for trench 2, so 53 minutes were spent preparing start areas rather than clearance. So actual work in the lanes was only for 441 minutes, giving an average advance of one metre in every 44 minutes.]

**Lanes 3 and 4:** All eight target mines were discovered by the deminer. Three had no damage. Five showed signs of having been struck on the side. One Type 72 showed signs of having been hit on the top by a prodder, not the spade. The damage was very light and not deemed likely to have initiated a real device.

The deminer worked a total (nominal) 540 minutes in the 10 metre area (including the extra square metre start “base-trenches” that are part of this method). The nominal advance was a metre every 54 minutes.

[This could be adjusted to subtract the time making the start trenches. -37 minutes for trench 1. -36 minutes for trench 2, so 73 minutes were spent preparing start areas rather than clearance, Actual work in the lanes was only for 467 minutes, giving an average advance of one metre in every 47 minutes.]

### **Best speed result:**

Average speed, in minutes per square metre: 49  
Safety to deminers (number of likely initiations): 1  
Safety to end user of land (number of missed mines): 0

### **Worst speed result:**

Average speed, in minutes per square metre: 54  
Safety to deminers (number of likely initiations): 0  
Safety to end user of land (number of missed mines): 0

**Average speed result:**

Average speed, in minutes per square metre: 51

Safety to deminers (number of likely initiations): 0.5

Safety to end user of land (number of missed mines): 0

**Best safety result:** no injury to deminer and no mines left.

**Worst safety result:** one injury to deminer, no mines left.

**QA potential:** internal QA/C required constant surveillance to ensure that the depth was maintained before backfill. Potential for external QA in some soils because of looseness of worked depth also possible (not possible when compacted during work).

**Expectations evaluated:** the speed was somewhat faster than anticipated and the clearance depth was maintained without variation at greater than the required depth (a spade head's width of 15cm+).

**Deminer opinion:** the deminers agreed that the spade excavation system was safe for deminers and end-users of the land, with some difference of opinion about the need to use water in advance for deminer safety. They also agreed that the method was thorough and could not leave mines behind. One felt that more training would have helped get the body accustomed to the method. [The deminers had been given two hours refresher training before the trials.]

## 5.7 Results: Standard NPA (Mozambique) excavation (Trial 7)

The NPA Mozambique excavation system and special tool was used to clear the trial areas by two NPA deminers under the supervision of an NPA Section Leader.

The NPA excavation tool and prodder are shown on the right.

**Expectations:** the method was expected to be thorough, but slow. It was anticipated that the clearance depth might vary.



**Lanes 1 and 2:** One mine was located, a GYATA at 1cm, undamaged. The total area cleared was 3.32 square metres (front of trench was at 3.5 but trench sloped back to 3.32). A total of 632 minutes work was carried out. The nominal speed of advance was 190 minutes per square metre. The clearance depth was not achieved, with the actual working depth measured as varying between 7 and 12cm.

The picture below right shows the shallow clearance depth achieved.

**Lanes 3 and 4:** Four mines were located, two Type 72s and two GYATAs. One mine was damaged on the side. The entire top of one mine was uncovered without any excavation of the sides. Pressure could have been applied directly downwards without leaving evidence. The total area cleared was five square metres over three days.

A total of 631 minutes of work were recorded so the nominal advance rate was at 126 minutes per metre, or two hours and six minutes per metre.

### Best speed results:

Average speed, in minutes per square metre: 126  
Safety to deminers (number of likely initiations): 0  
Safety to end user of land (number of missed mines): 0

### Worst speed results:

Average speed, in minutes per square metre: 190  
Safety to deminers (number of likely initiations): 0  
Safety to end user of land (number of missed mines): 0 (depth not maintained)

### Average speed results:

Average speed, in minutes per square metre: 158  
Safety to deminers (number of likely initiations): 0  
Safety to end user of land (number of missed mines): 0 (depth not maintained)

**Best safety result:** no injury to deminer and no mines left.

**Worst safety result:** no injury to deminer, up to 4 mines left (projected).

**QA potential:** internal QA/C required constant surveillance to ensure that the depth was maintained before backfill. Potential for external QA in some soils because of looseness of worked depth also possible (not possible when soil re-compacted during work).

**Expectations evaluated:** the method was slower than anticipated, and one deminer's failure to maintain the clearance depth would have certainly resulted in missed mines had there been any in the area worked. An ineffective Section Commander may have influenced the deminer's maintenance of depth.

**Deminer opinion:** the deminers agreed that the NPA-Mozambique excavation system was safe for deminers and end-users of the land, with some difference of opinion about whether it was only easy on soft ground. The slowest deminer claimed that the method was fast, and that the maintenance of a clearance depth depended on the depth at which mines were found.



## 5.8 Results: Standard Mattock excavation (Trial 8)

The Enxada (Mattock) system was used to clear the trial areas by two ADP deminers under the supervision of a Section Leader. The Enxada excavation method involved the use of prodders and an enxada (mattock).

**Expectations:** the method was expected to be thorough, and relatively fast. It was anticipated that depth might vary and mines might be struck on the top.

**Lanes 1 and 2:** The Deminer located seven of the eight mines concealed in the area. The missed mine was at the extreme edge of the lane and his failure to maintain straight edges to the lane resulted in it being missed. The excavation method included no “out-of-lane” overlap, and the QA failed to spot the deviation from the line. However, the method required that lanes be joined all along their sides and so the mine should have been located when the area had been extended by an adjacent lane. The deminers did not consider this a missed mine, and because the edge of the cut lane was clear, I am treating it as having been outside the area.

One mine was entirely undamaged on recovery. Five had damage on the side. One Type 72 had deep cuts through the bottom edge (which could have pushed the mine upward in the ground and caused a detonation, but this is thought unlikely). A GYATA had been struck on the top with a 12mm deep cut into the wood and it is believed that this mine would certainly have initiated.



The damaged GYATA surrogate is shown on the left (with the latex witness plate peeled back).

The deminer worked a recorded 309 minutes in the area), giving him a nominal rate of advance of a metre every 30 minutes.

**Lanes 3 and 4:** All eight mines in lanes 3 and 4 were located during the trial. Four mines were recovered undamaged. Two mines had light impact damage on the sides. One GYATA had been struck on the top corner in a manner that was likely to have initiated the mine (the GYATA's pressure plate extends to the edge of the top surface). One Type 72 had been broken into two by a heavy impact on the top corner, extending 1.5cm onto the top of the mine, and it was felt that this blow would have resulted in a detonation.

The deminer worked in the area for a recorded 375 minutes and so progressed at a nominal rate of one metre every 37 minutes

### Best speed result:

Average speed, in minutes per square metre: 30  
Safety to deminers (number of likely initiations): 1  
Safety to end user of land (number of missed mines): 0

### Worst results:

Average speed, in minutes per square metre: 37  
Safety to deminers (number of likely initiations): 2  
Safety to end user of land (number of missed mines): 0

**Average results:**

Average speed, in minutes per square metre: 33

Safety to deminers (number of likely initiations): 1.5

Safety to end user of land (number of missed mines): 0

**Best safety result:** one injury to deminer and no mines left.

**Worst safety result:** two injuries to deminer, no mines left.

**QA potential:** internal QA/C required constant surveillance to ensure that the depth was maintained before backfill. Potential for external QA in some soils because of looseness of worked depth also possible (not possible when compacted during work).

**Expectations evaluated:** the method was relatively fast, and mines were struck on the top as anticipated. Depth was maintained and mines were not missed due to any variation in maintenance of the 13cm depth required (which was frequently exceeded). One mine was missed because the edge of the lane was not kept straight, but this has been discounted from the result because an adjacent lane would have excavated that area.

**Deminer opinion:** the deminers agreed that the enxada (mattock) excavation system was unsafe for deminers because of the effort required and the way in which the tool had to be used (because of its design). They agreed that all mines to the required depth would be found. All agreed that the method was fast, but inherently dangerous for the deminer. All felt that increased training would not have made their use of the method any safer. [The deminers had been trained in the method before the trials.]

## 5.9 Results: Prodding (Trial 9)

In a second "control test", ADP (low-friction) prodders were used to determine the actual depth that could be prodded in the conditions prevalent at the trial site.

**Expectations:** It was anticipated that it would be impossible to achieve a 10cm depth in that ground. [The length of the prodder insertion does *not* equal the depth to which the ground is interrogated.]



A Type 72 surrogate mine was concealed at 4, 6 and 8cm in both areas. One deminer found the two mines at 4 and 6cm. One deminer found only the mine at 6cm. Damage was found on the top of all mines found using the prodders. The missed mines were recovered later but in an uncontrolled way. All later recovered mines were badly damaged on the top, but this may have occurred during their recovery.

There was sustained heavy rain between the two stages of the trial: this affected ease of ground penetration.

Before the rain, the average penetration lengths were 6.8cm and 12.9cm: the lowest penetration lengths were 6cm and 9cm. Guaranteed coverage to a **depth** of 3 and 4.5cm was achieved. Both deminers missed a mine at 8cm and one (the one prodding with deeper penetrations) missed a mine at 4cm. The deminer only prodding to a guaranteed depth of 3cm located the mine at 4cm after prodding onto its top.



After the rain, the deminer in lane one increased his average penetration length from 6cm to 9cm. The deminer in Area 2 increased his average penetration length from 12.9 to 17.5cm. Allowing for the different technique used (rotating prodder yielding an average 3cm increase in penetration) the average increase caused by rain-water was: Area 1: none, Area 2: 2.4cm.

### Best results:

Average depth achieved: 4.5cm

Average depth achieved after low-friction twist applied: +5.3cm length of penetration (not depth)

Safety to deminer and end user of land (number of missed mines): 2

### Worst results:

Average depth achieved: 3cm

Average depth achieved after low-friction twist applied: +2.2cm length of penetration (not depth)

Safety to deminer and end user of land (number of missed mines): 1

### Average results:

Average depth achieved: 3.75cm

Average depth achieved after low-friction twist applied: +3.75cm penetration (not depth)

Safety to deminer and end user of land (number of missed mines): 1.5

**Best safety result:** two injuries to deminer, one mine left.

**Worst safety result:** one injury to deminer, two mines left.

**Expectations evaluated:** the expectations were confirmed and, even after heavy rain, prodding was unable to achieve a clearance depth close to 10cm in that ground.

## 6 Conclusions

**area-excavation:** in this report, the term “*area-excavation*” is used to describe the process of removing the entire ground surface to a predetermined depth, and locating any concealed mines or ERW in the process.

**detector-signal investigation:** in this report, the term “*detector-signal investigation*” is used to describe the process of locating metal with a metal-detector, then unearthing and recovering that metal from a discrete location.

The principal purpose of the trials was to provide quantitative and qualitative data allowing a comparative assessment of the “efficiency” of selected manual demining systems, with a qualitative overview applied to the results. The objective was to achieve consensus over conclusions that, in context, could be compelling. While a number of the conclusions are no more than compelling inferences, some carry more logical compulsion than was anticipated.

“Efficiency” was to be measured in terms of speed, the location of targets within a predefined depth, the safety of the deminer while conducting the varied drills, and the safety of the end-users of the land.

### 6.1 AVS Conclusions from the results

All the conclusions of these trials are presented as reliable inferences drawn from the available evidence. The constraints on the trial design and execution prevent it being possible to claim any definitive conclusions because variables were not entirely controlled, and the number of repetitions was severely limited.

The following statements can be made as a result of the trials.

**Trial 1:** showed that an area containing more than 7 metal signals per square metre could be cleared to a depth of 13cm using the Minelab metal detector while using conventional tools for detector signal-investigation.

**Trial 2:** showed that attaching a magnet to a hand-tool used for detector signal-investigation when clearing an area containing more than 7 metal signals per square metre could cut the time required to achieve “metal-free” status in half.

**Trial 3:** showed that using a magnetic Brush-rake when clearing an area containing more than 7 metal signals per square metre could cut the time required to achieve “metal-free” status to slightly more than third. When the result is compared with that in trial 4, where the signal density was reduced to two in each square metre, it can be seen that the magnetic Brush-rake reduced the time it took to clear a high fragment density area to the time it took to clear a low fragment density area with only a metal-detector.

**Trial 4:** showed that the accuracy of pinpointing a metal-detector reading is not critical to the location of devices using conventional detector signal-investigation routines. [It did not reliably show the effect that a pinpointing inaccuracy would have on deminer safety.]

**Trial 5:** showed that the REDS area-excavation system could be used successfully in the trial area, and that it was the only area-excavation process that allowed for realistic field QA without constant supervision. It was also the method that gave most confidence in total clearance (including small items such as fuzes) to a depth because of the soil-sifting process involved. While slow, it was not the slowest method (and was almost a third faster than the slowest method).

**Trial 6:** showed that the controlled use of a conventional garden spade in area-excavation was the fastest area-excavation method under trial. Deminer safety while using it was the same as the REDS system, and both were better than other excavation methods.

**Trial 7:** showed that the use of a short purpose-made trowel for area-excavation was not efficient in terms of speed. Its poor safety result was due to inadequate field supervision and so would not necessarily apply outside the trial situation. This was the slowest method of all those compared.

**Trial 8:** showed that the use of a mattock in area-excavation was the fastest of those compared, but also the most dangerous to the deminer. Despite its relative speed compared to other area-excavation methods, it was half as slow again as the clearance of the area using a metal-detector and magnetic tools.

**Trial 9:** confirmed that prodding could not achieve a realistic depth and was the most dangerous method of those tried in terms of both deminer safety and of leaving mines behind.

From these, I draw the following conclusions that I believe have widespread applicability:

1. The need to resort to area-excavation because of a high density of metal-detector signals is rare. The number of metal-detector signals per square metre that can be investigated using conventional signal-investigation routines without resorting to area-excavation exceeds 7 (although the process may be slow, it was faster than two of the area-excavation methods trialled).
2. The use of magnetic tools to help process an area after metal-detector use and prior to signal-investigation can so reduce the need to conduct signal-investigation drills that the use of a metal-detector becomes the most efficient approach in areas with a high signal density. This also means that QA/C could be conducted, and so has both speed and confidence advantages.

The trials were conducted using aged Minelab detectors. The deminers were familiar with the detector and usually able to discriminate detector-readings well. If different detectors were used, or the experience of the deminers was lower, there may be an increased advantage in using magnets to reduce the number of detector-signals that must be investigated.

3. It is not necessarily safer to conduct area-excavation than detector-signal investigations in high signal-density areas. When magnets are used, it can be safer to use metal-detectors, magnets and conventional signal-investigation routines.
4. The use of an enxada (mattock) for area-excavation is fast but potentially more dangerous to the deminer than other methods. (A number of recorded demining accidents with a mattock add weight to this view: see the DDAS.)
5. Prodding, using a prodder only, is an inefficient means of locating concealed mines at any depth. It is the most dangerous method of mine location for the deminer and for the end-user of the land. (See also Trevelyan's<sup>2</sup> findings. His trials did not include any assessment of damage to targets or of the safety to the deminer, but he did find that, even in "ideal" soft, dry sand, prodding to depths of 10cm was "unreliable".
6. If area-excavation is to be used in an area similar to the Trial ground, the most efficient method in terms of both speed and safety is to use a garden spade to slice thin layers of earth from the side of a vertical excavation face.
7. The individual deminer's approach has a profound effect on safety, and this is clearly negative when the deminer's approach included a desire to be fast. (See also the evidence in the DDAS.)
8. The checking of each man's work by a supervisor is essential to achieve confidence in complete clearance.
9. The diameter of a "halo" used to measure a successful "detection" with a metal detector as determined in the CEN Workshop Agreement CWA 14747:2003. (<http://humanitarian-security.jrc.it/demining/cw07/>) was not appropriate for the GYATA target (simulated as it was in these trials). This implies that the details of the CEN test may require revision.
10. The expectation that the full demining process would yield better results than those from a CEN detection "reliability test" was confirmed, so implying that the details of CEN test require revision.

---

<sup>2</sup> Statistical Analysis and Experiments in Manual Demining, J. Trevelyan, UWA. 2003  
<http://www.mech.uwa.edu.au/jpt/demining/reports/Trevelyan%20EUDEM-SCOT2003%20030618.pdf>

## 6.2 AVS Recommendations

The results of these trials lead to several recommendations that may help field deminers to increase their efficiency (in terms of safety and speed).

1. I recommend the use of purpose-made magnets to remove fragmentation after a metal-detector has signalled and before signal-investigation routines are used. There is evidence that this can significantly increase the speed with which the land is processed.
2. When metal-detectors are used, I recommend the deployment of experienced and responsible supervisors to fully QA each deminer's work. There is evidence that this can increase safety for both deminers and the end-users of the land.
3. I recommend the use of good GC metal-detectors (and their replacement as soon as they become "unstable") to ensure thorough clearance and so increase safety for the deminer and the end-user of the land.

Because of the apparent attraction of No 1 above, tests of the safety parameters of the magnet-based tools (especially the most successful, the magnet-Brush-rake) are highly desirable. When the parameters surrounding their safe use can be defined with greater confidence, demining groups may be expected to adopt the tools fairly readily despite the nascent conservatism with the HD community. This is because the cost of magnet-Brush-rakes is low, and their potential to increase efficiency is high.

This trial could usefully be repeated with more time for preparation, over a wider area, and with a far higher number of repetitions. The results of such a trial would be more compelling and so harder for demining groups that might feel obliged to change their methods or tools if they accepted the findings to dismiss or ignore.

### 6.2.1 AVS Lessons learned for future trials

From the design of the targets to the use of monitors from several organisations, the trials went off remarkably well. That said, there were some aspects, from budget constraints to trial-design, that could usefully be improved in any future trials of manual demining techniques/tools.

Future trials should be designed so that there is no reason for a deminer to perceive an advantage in speed (there should be no extra rest-period while he waits for the next trial to start or another deminer to "catch-up").

Comparative trials should be designed so that each deminer uses every technique/tool under assessment, so reducing the impact on the results of any individual deminer's "approach".

When a future trial is of a complete system (or "method"), including the standard field QA, the deminers and their QA personnel should be given "refresher training" in the technique prior to the trial – even when that technique is one that they feel familiar with.

Monitors for trials should be trained to keep the records appropriately, with extended periods of practice that cover at least one full working session. Monitors should also understand their full responsibility with regard to writing up results in a timely manner.

Monitors should be selected so that their personal presence does not influence the performance of the deminers. This probably means that all monitors should be individuals not known to the deminers prior to the trial.

## 6.3 Conclusions from observer organisations

QinetiQ and BAM both presented reports on the trials after the programme had finished and after AVS had completed this report. While their reports and conclusions were generally in agreement with those expressed in the body of this report, several conclusions were made that are at variance to this author's view.

### 6.3.1 BAM conclusions from the results

The conclusions made by BAM and presented here were subsequently revised. The revised conclusions are reproduced in Annex E.

BAM calculated speed and performance in a slightly different way. Bam declined to make general conclusions, except for Trial 4 about which they originally stated that:

*“Some argued that the results of a full process (including investigation of each signal) would always be higher than the results of a reliability test. Results of these trials do not confirm such a prediction.”*

Further, BAM added:

*“there are no essential differences between the results of these reliability trials and the full Trial 4.”*

[Both of these assessments conflict with the assessment of the results made by AVS above. BAM later changed their view to that recorded in Annex E but that text was delivered too late for integration.]

### **6.3.2 BAM Lessons learned for future trials**

The following comment on future comparative trials has been received from BAM:

*It has been shown in many metal detector trials that the influence of the human factor is very significant. The same has proven to be true in these manual demining trials.*

*To compare the methods efficiently, each method should be tested with the same deminers and the number of deminers should be as large as possible.*

*If two methods need to be compared, they should be performed at the same time if possible.*

*It is impossible to ensure that all conditions are the same for all methods tested, but it is possible to minimise the impact of the uncontrolled factors by randomising the design. For example, if two methods would need to be compared and each method would be tested in four lanes, than the location of the lanes on a testing area should be random or quasi-random. Grouping four lanes for Method 1 together would not be the best choice, because there might be a systematic difference between the soil on that area and the soil elsewhere.*

*A more complex multivariable data analysis would give more insight in the influence of the density of mines, time of day, etc. However, influencing variables need to be defined before the trials are designed and they should guide the design, so that the results can be used in the analysis.*

### **6.3.3 QinetiQ conclusions from the results**

1. The effects of the differing skills and abilities of the deminers were not taken into account in this trial.
2. The specific results from this trial apply to the specific conditions that were encountered in the trial lanes at ADP Training Centre in Moamba in Mozambique.
3. The excavation methods without metal detectors using the spade and enxada are quicker than the ADP SOP clearance method because the metallic scrap does not have to be cleared when excavating the whole mine lane.
4. The use of magnets attached to clearance tools significantly speeds up the rate of advance when compared with either the standard ADP SOP method or the excavation methods because the magnets remove the surface and shallow magnetic scrap metal fragments.
5. Excavation methods are less likely to miss deeper buried mines than methods using metal detectors.

[AVS does not believe that there is sufficient evidence to support Statement 5 as a general rule.]

### **6.3.4 QinetiQ recommendations**

1. Further trials are required in order to complete the analysis of manual demining techniques and to validate the results by conducting all tests with more deminers and in a variety of environmental conditions.
2. Further data is required to fully understand the breakdown of the constituent parts of the clearance processes.

## Annex A: References

The following references have been variously used to inform the content of this report, and to dictate its approach:

- a) IMAS 03.30. Guide to research of mine action technology.
- b) IMAS 03.40 Test and evaluation of mine action equipment
- c) Database of Demining Accidents (DDAS), GICHD for UNMAS
- d) CEN Workshop Agreement CWA 14747:2003. (<http://humanitarian-security.jrc.it/demining/cw07/>)
- e) *Statistical Analysis and Experiments in Manual Demining*, J.Trevelyan, UWA. 2003  
<http://www.mech.uwa.edu.au/jpt/demining/reports/Trevelyan%20EUEM-SCOT2003%20030618.pdf>
- f) *Reliability Tests for Demining*, Workshop proceedings, 2003: Federal Institute for Materials Research and Testing, Berlin, Germany
- g) *International Pilot Project Technical Cooperation (IPPTC)*, Defence Research Establishment Suffield CA, Joint Research Centre (JRC), EC, Landmacht Directie Materieel NL, Qinetiq UK, US Dept. of Defense USA. Access via:  
<http://www.itep.ws/reports>
- h) *Metal-detector Handbook for Humanitarian Demining* Pub EU, 2003, ISBN 92-894-6236-1. Distributed by UNMAS, GICHD, ITEP and the EU. Authors, Guelle, Smith, Bloodworth, Lewis, 2003.
- i) *Accidents and incidents in Humanitarian Demining (HD), the need to collect accurate records for meaningful analysis*, Andy Smith, May 2002. Paper for Third European-American Workshop on Reliability of NDE and Demining, NDE, September 2002.
- j) *What use is a database of demining accidents?* Andy Smith 2002. James Madison University, Journal of Mine Action , Issue 6.2, Summer 2002, James Madison University, Virginia USA. <http://maic.jmu.edu/journal/index/index.htm>
- k) *Developing safer demining handtools in Zimbabwe*: Andy Smith 2002. James Madison University, Journal of Mine Action , Issue 6.2, Summer 2002, James Madison University, Virginia USA. <http://maic.jmu.edu/journal/index/index.htm>
- l) *Database of Demining Accidents* - Andy Smith 2001: Geneva International Centre for Humanitarian Demining (GICHD) 2002: a CD database of incidents that have occurred in HD (including incident reports) from the Gulf to the present. CD available to demining researchers from GICHD at no cost.
- m) *The facts on protection needs in humanitarian demining* - Andy Smith, edited loosely. James Madison University, Journal of Mine Action , Issue 4.2, Summer 2000, Virginia, USA - <http://maic.jmu.edu/journal/4.2/Focus/PN/protectneeds.htm> Translated into Spanish by OAS at <http://www.upd.oas.org/demining/relatedarticles.htm>  
Online: ISSN 1533-6905 Print: ISSN 1533-9440
- n) *Injuries that occur in Humanitarian Demining* - Andy Smith 2000, Landmine Monitor Report 2000, p1074, Human Rights Watch, USA. Email [lm@icbl.org](mailto:lm@icbl.org)
- o) *Development and demonstration of protective equipment items for use in Humanitarian Demining* - Andy Smith, US Army RDEC CECOM NVESD, Washington, USA, April 2000
- p) *Observations & Inferences - Reflections on the AVS Database of Demining Incident Victims* - included with the software, Andy Smith, AVS, June 1999. Published by Mines Action Canada.
- q) *Database of Demining Incident Victims* - Vols 1-3 - US Army RDEC CECOM NVESD, Andy Smith, June 1999.
- r) *Demining in Bosnia Herzegovina*, US Army RDEC CECOM NVESD, Andy Smith, June 1999.

- s) *Demining in Cambodia*, US Army RDEC CECOM NVESD, Andy Smith, March 1999.
- t) *Demining in Southern Africa*, US Army RDEC CECOM NVESD, Andy Smith, January 1999.
- u) *Demining in Afghanistan*, US Army RDEC CECOM NVESD, Andy Smith, September 1998.
- v) *A demining study in Mozambique*: November 1995 - University of Warwick DTU, UK, Working Paper 48, Andy Smith, 1995.
- w) *Standards and Safety in Humanitarian Demining* - paper presented at (in proceedings of) conference entitled "Standards & Measures of Success" James Madison University, 4-7 October 1998.
- x) *Current situation and perceived needs for head and face protection in humanitarian demining* - in proceedings of "The design and Integration of Helmet Systems" Conference held at the Sheraton Tara Hotel, Framingham, MA, USA on 2-5th Dec 1997: Journal of Humanitarian Mine clearance, James Madison University, Feb 1998, Virginia, USA - <http://maic.jmu.edu/journal/2.1/smith.htm> Online: ISSN 1533-6905 Print: ISSN 1533-9440
- y) *Sustainable methods for clearing landmines after conflicts* - Royal Engineers Journal August 1996 (Vol 110, No.2) p160, Dr T.H.Thomas & Andy Smith.

## **Annex B: Trial records AVS, November 2004**

What follows are the records made during the trials held at the ADP Deminer Training Camp at Moamba, Maputo Province, Mozambique during October and November 2004. The trial was devised and the trial area prepared by AVS with assistance from BAM. The trials were monitored by representatives of BAM, QinetiQ, ADP and AVS.

### **Trial 1: metal detector and standard tools**

Two deminers worked on two five metre lanes each. Target mines were concealed at random positions, eight in each deminer's area. The Minelab metal-detector was used. A stock of batteries was held, allowing batteries to be replaced as required.

All mines were found: one by the QA.

### **Trial 1, Lanes 1 and 2, 2<sup>nd</sup> November 2004, ADP Team 1**

**Monitor:** Neville Goulton

**Deminer:** Carlos Tembe

**Section Commander:** Fernando Laice

7 mines were located by the deminer, with the 8<sup>th</sup> located during the QA process.

Two 5m lanes were cleared in 598 minutes, so giving an average rate of advance of 60 minutes per square metre.

One GYATA showed tool marks in several places on the side of the mine.

When the top of the discovered mines was exposed, there was heavy prodder damage to the top of one Type 72, with wood penetration to approx. 4mm.

07:12 Advance red-stick to 0.5m

07:14 Uses detector

Trims undergrowth with shears was light

Prods

Trowel/excavation/secateurs

07:29 Fragment found at 0.25m x 0.5m

07:31 Advance white stick to 0.5m

Advance red stick to 1m

07:32 Detection 0.8m x 0.3m in

07:44 Rest Break

.....

08:04 Restart work

08:07 Fragment found 0.8m x 0.4m

08:08 Detection 0.9m x 0.2m

08:11 **MINE** located 0.9 x 0.2m, depth 2cm: no impact on top, Type 72 [AVS: confirmed]

08:13 Continue after mine removal

08:14 Advance White stick to 0.7m

Red stick to 1.1m  
08:15 Detection at 1m x 0.8m  
08:33 Rest break  
.....  
Water applied to working area during rest break  
08:54 Restart work  
09:01 **MINE** located at 1.0 x 0.2m (depth 12cm) GYATA  
Slight corner damage on top of mine. [AVS: Light damage to rubber/latex]  
09:04 Continue after mine removed  
Advance White stick to 1.1m  
Red stick to 1.8m  
09:06 Detection at 1.4 x 0.7m. Fragment found  
09:07 Detection at 1.5 x 0.7m Fragment on surface found at 1.6 x 0.7m  
09:10 Two fragments found at 1.7 x 0.1m (fragments on surface)  
09:23 Stop for rest break  
.....  
09:44 Restart work  
09:45 Detection at 1.6 x 0.5m  
10:01 Fragment found at 1.6 x 0.5m (2-3cm deep)  
10:02 Detection and surface fragment located 1.8 x 0.9cm  
10:04 Advanced white stick to 2m  
Advanced red stick to 2.6m  
10:06 Detection and two surface fragments found at 2.1 x 0.7m  
Advanced white stick to 2.3m  
Advanced red stick to 2.8m  
10:07 Detection and surface fragment found at 2.7 x 0.3m  
10:08 Advanced white stick to 2.6m  
Advanced red stick to 3.1m  
10:09 Four surface fragments located and removed  
Detection and fragment found and removed  
Detection and fragment found and removed  
10:10 Advance red stick to 3.5m  
10:11 Fragment found and removed  
10:12 Advance white stick to 3.4m  
Advance red stick to 4m  
10:13 Stop for rest break  
.....  
11:02 Restart work  
11:05 Detect and locate fragment at 3.8 x 0.1m  
11:06 Detect and locate fragment at 3.7 x 0.7m

Detect and locate fragment at 3.7 x 0.6m

11:07 Detection at 3.9 x 0.3

11:15 Small root encountered – approx 7-8mm diameter.  
Root cleared

11:31 Fragment located at 3.9 x 0.3

11:32 Stop for rest break

.....

Water added to working area

During break Section Commander checked the cleared area.

Fragment found at 1.5 x 1.0m

Detection at 2.1 x 0.4m

11:43 **MINE** located at 2.1 x 0.4: Type 72, 12cm deep  
No evidence of impact on top of mine. [AVS: confirmed]  
Section Commander did not complete QA process after locating mine.

[QA presumed to have ended 2 minutes after mine located.]

11: 51 Restart work

Deminer started from the point where the mine was found by the Section Commander, so QA process was completed after all.

11:55 Detection at 4.1 x 0.2m

12:12 Advanced red stick to 4.4m  
Advanced white stick to 3.8m

12:14 Fragment found at 4.2 x 0.2m

12:15 Detection at 4.4 x 0.1m  
Advanced white stick to 4.1m

12:17 Detection at 4.2 x 0.6m

12:21 Stop for rest break.

.....

12:42 Restart work

12:52 Advanced white stick to 3.9m

13:01 Fragment located at 4.2 x 0.6m

13:02 White stick advanced to 4.1 metres  
Red stick advanced to 4.7m

13:11 End of work

The Deminer and QA worked for 221 minutes.

Approximately 4.1 metres were cleared

Two mines were located by the deminer, one Type 72 and one GYATA. A third (Type 72) was also located.

26 fragments were located, of which one was non-magnetic

One mine was missed in clearance and picked up by the internal QA within the standard ADP system. That mine was a minimum metal mine buried at 12cm to the top of the mine.

There were 6.3 fragments to the square metre.

Add the three mine targets to the fragment total and there were 29 indications in 4.1 metres, so 7 indications to the square metre.

**Trial 1, Lanes 1 and 2**, November 3<sup>rd</sup>, ADP Team 1

**Monitor:** Manuel Raul Django

**Deminer:** Carlos Tembe

**Section Commander:** Fernando Laice

06:45 Start work

07:09 Metal piece found (4.25 x 20cm)

07:15 Stop for rest break

.....

07:34 Restart work

07:38 Advance white stick to 410cm

07:40 Metal piece found 460 x 30cm

07:41 Advance white stick to 435cm

07:54 Metal piece found 480 x 50cm

08:05 Stop work for rest break

.....

08:25 Restart work

08:30 Metal piece found 470 x 50cm [water used]

08:32 Lane 1 is completed [5 metres]

Start Lane 2

08:38 Metal piece found (10 x 50cm)

08:41 Metal piece found (40 x 20cm)

08:45 Metal piece found (40 x 50cm) [water used]

08:54 Stop for rest break

.....

09:15 Restart work, apply water

09:25 Metal piece found (25 x 5cm)

09:38 Metal piece found (30 x 90cm)

09:45 Stop for breakfast break

.....

10:34 Work restarts

10:57 Metal piece found (30cm x 1m)

10:59 Advance white stick to 20cm

11:08 Stop for rest break

.....

11:25 Restart work

11:41 Advance white stick to 30cm

11:55 Stop for rest break, apply water  
.....  
12:15 Restart work  
12:22 **MINE** located, GYATA 70 x 20cm, no damage [AVS: confirmed]  
12:26 Advance white stick to 65cm  
12:28 Metal piece found (75 x 50cm)  
12:29 Metal piece found (90 x 45cm)  
12:45 Stop work

214 minutes worked

Django's calculations:

1.4 square metres cleared

9 magnetic fragments, plus one non-magnetic located.

3 buckets of water used

1 GYATA found at 12cm.

### **Trial 1, Lanes 1 and 2**, November 4<sup>th</sup>, ADP Team 1

**Monitor:** Mate Gaal

**Deminer:** Carlos Tembe

**Section Commander:** Fernando Laice

Comment: The soil is wetter than in the surrounding area – implying that the deminer had poured water on the lane prior to the start of the trial.

06:51 Start work [white stick at 35cm]  
07:01 Found a piece of munition at depth greater than 10cm. This was not a fragment placed for the trial.  
07:10 White stick to 80cm  
07:18 White stick to 125cm  
07:20 Stop for rest Break  
.....  
07:41 Start work  
07:53 Detector signal (about 230, 5)  
07:54 Section Commander rolls up the right marking tape to 150cm and puts the peg 15-20cm too far to the right. Position of peg: (x, y) (150, -15).  
[The Section Commander is now watching this deminer constantly because the other deminer in the team has finished his task.]  
08:05 **MINE** located at 150, 10. Type 72 at 12cm: no damage [AVS: Heavy strike to the top discovered after latex removal – apparently struck by the trowel and wood penetrated to 4mm: initiation presumed.]  
08:09 Deminer continues work  
Advance white stick to 185cm  
08:10 Pours two buckets of water ahead of the stick [over the whole lane]  
Stop for rest break

.....

08:30 Start work

08:39 **MINE** located at 220, 20. GYATA at 1cm, not damaged [AVS: confirmed]

08:41 Deminer continues work

08:43 Advance white stick to 250cm

08:55 Advance white stick to 300cm

08:59 Advance white stick to 320cm

Stop for rest break

.....

09:21 Start work

09:30 **MINE** located at 350, 90. GYATA at 1cm: no damage [AVS: confirmed]

09:31 Work continues

09:32 Advance white stick to 375cm

09:37 Advance white stick to 385cm

09:43 **MINE** located at 420,30. 12cm, Type 72, no damage [AVS: confirmed]

09:44 Deminer continues work

09:46 Advance white stick to 425cm

09:50 Stop for breakfast break

Deminer empties a bucket of water on the last metre of the lane

.....

10:40 Work starts

11:09 Deminer finishes Lane 4

Deminer stops work

Section Commander does a QA detector check

Section commander locates one fragment

11:27 Section Commander finishes QA detector check.

Mate's calculations: 26 fragments found

Deminer and QA cleared 4.65 square metres.

### **Trial 1, Lanes 3 and 4, 2<sup>nd</sup> November, ADP Team 1**

**Monitor:** Manuel Raul Django

**Deminer:** Helder Martins

**Section Commander:** Fernando Laice

All 8 mines were located by the deminer.

Two 5 metre long lanes were cleared in 474 minutes, so giving a nominal rate of advance of approximately 47 minutes per square metre.

When the top of the discovered mines was exposed, there was no evidence of impact strikes on the top of the mines. [Confirmed in double check.]

07:12 Start

07:27 Investigate and find Frag at 10cm x 70cm  
07:42 Stop for rest break  
.....  
08:02 Restart work  
08:17 **MINE** located, GYATA, 35cm x 80cm (No damage to top of mine) [AVS: confirmed]  
08:20 Restart after mine removal  
Advance white stick to 30cm  
08:23 Investigate and find fragment at 35cm x 90cm  
08:31 Stop for rest break  
.....  
08:51 Restart work  
09:12 Investigate and find frag at 80cm x 80cm  
09:14 Advance white stick to 45cm  
09:18 Investigate and find frag at 85 x 90cm  
09:20 Moved white stick back to 20cm  
09:21 Stop for rest break  
.....  
09:41 Restart work  
10:00 Investigate and find frag at 50cm x 40cm  
10:02 Advance white stick to 50cm from start  
10:09 **MINE** located Type 72 mine at 75cm x 20cm (No damage on top of mine)  
[AVS: confirmed]  
10:11 Stop for breakfast break  
.....  
10:59 Restart work  
11:01 Moved white stick forward to 80cm from start  
11:13 Investigate and find fragment at 1 metre x 10cm  
11:14 Advance white stick forward to 85cm from start  
11:21 Investigate and find fragment at 120cm x 10cm  
11:22 Investigate and find fragment at 120cm x 30cm  
First square metre cleared  
11:29 Investigate and find fragment at 125cm x 40cm  
11:30 Stop for rest break  
.....  
11:49 Restart work  
11:50 Advance white stick to 110cms from start  
11:55 Investigate and find fragment at 140cm x 70cm  
11:56 Investigate and find fragment at 150cm x 50cm (fragment on surface)  
11:57 Advance white stick to 1.5m from start  
12:02 Investigate and find fragment at 185cm x 30cm

- 12:03 Investigate and find fragment at 190cm x 80cm (fragment on surface)  
Advance white stick to 1.75m from start
- 12:04 Investigate and find fragment at 1.95m x 85cm (fragment on surface)
- 12:05 Advance white stick to 1.9m from start
- 12:06 Second square metre completed
- 12:19 Stop for rest break
- .....
- 12:39 Restart work
- 12:42 Investigate and find fragment at 2.25m x 40cm (fragment on surface)
- 12:43 Investigate and find fragment at 2.20m x 50cm (fragment on surface)
- 13:04 Investigate and find fragment at 2.5m x 40cm
- 13:05 Investigate and find fragment at 2.7m x 70cm (fragment on surface)
- 13:06 Advance white stick to 2.6m from start
- 13:08 Investigate and find fragment at 3m x 70cm
- 13:09 Investigate and find fragment at 3m x 50cm (fragment on surface)
- 13:10 Whistle for end of work.

The Deminer worked for 211 minutes

Approximately 3.3 metres were recorded by the monitor as having been worked on, but only 2.6 metres were cleared (as marked by position of the white stick).

Two mines were located by the deminer, one Type 72 and one GYATA.

22 fragments were located, of which one was non-magnetic. Three fragments were found in advance of the white stick (cleared area) so they should be removed from the calculation for the fragment density of the cleared area.

There were 7.3 fragments to the square metre.

Add the two mine targets to the fragment total and there were 21 indications in 2.6 metres, so 8 indications to the square metre.

### **Trial 1, Lanes 3 and 4, November 3<sup>rd</sup>**

**Monitor:** Paulino Tule Gove

**Deminer:** Helder Martins

**Section Commander:** Fernando Laice

- 06:45 Start trial [First round 325cm]
- 06:46 Rechecks lane 3 and investigates reading
- 06:53 Proceeding with clearance
- 06:54 Metal piece found
- 06:57 Metal piece found
- 07:04 Metal piece found
- 07:07 Metal piece found  
Advance white stick to 360cm
- 07:08 Metal piece found

07:09 Metal piece found  
07:11 Move white stick back to 380cm  
07:15 Stop for rest break  
.....  
Section Commander does internal QA  
07:20 Section Commander finishes internal QA  
07:34 Work restarts  
07:46 **MINE** discovered 440cm, GYATA, 1cm deep, no damage [AVS: confirmed]  
07:50 Lane 3 is completed [5m]  
07:51 Start on Lane 4  
07:59 Metal piece found  
08:01 Metal piece found  
08:03 Metal piece found  
08:04 Advance white stick to 45cm  
Metal piece found  
08:05 Stop for rest break  
.....  
Section Commander performs internal QA.  
08:15 **MINE** located by Section Commander, T72 at 12cm, 400cm. Mine had white scratch on side, Lane no.3, [AVS: damage confirmed]  
08:17 Section Commander completes QA  
08:25 Work restarts on Lane 4  
08:27 Advance white stick to 30cm  
08:37 Mine uncovered at 12cm, 50cm, No damage  
08:42 Advance white stick to 95cm  
08:43 Metal piece found  
08:46 Metal piece found  
08:54 Stop for rest break  
.....  
08:54 Section Commander does internal QA  
Section Commander finds a metal piece  
[No record of when QA ended, presumed 5 minutes duration]  
09:15 Work restarts  
09:16 Metal piece found  
09:28 **MINE** discovered, GYATA, 1cm depth, 1250cm, no damage [AVS: confirmed]  
09:33 Metal piece found by metal detector  
09:34 Advance white stick to 150cm  
Metal piece found by metal detector  
09:44 Start rest break (breakfast)  
.....

10:34 Restart work  
10:35 Preparation  
10:37 Start in lane  
10:45 Metal piece found  
10:50 **MINE** discovered. Type 72, 12cm, 200cm, side scratched [AVS: confirmed]  
10:55 Advance white stick to 175cm  
10:56 Metal piece found  
11:07 Stop for rest break  
.....  
11:25 Restart work  
11:26 **MINE** discovered, Type 72, 1cm, 95cm not damaged [AVS: confirmed [?? Position]  
11:28 Metal piece found by metal detector  
11:42 Metal piece found by metal detector  
11:43 Metal piece found by metal detector  
Advance white stick to 235cm  
11:48 Metal piece found by metal detector  
11:49 Advance white stick to 260cm  
11:50 Metal piece found by metal detector  
11:52 Metal piece found by metal detector  
11:53 Metal piece found by metal detector  
11:54 Metal piece found by metal detector  
11:55 Stop for rest break  
.....  
12:15 Work restarts  
12:17 Metal piece found by metal detector  
12:18 Metal piece found by metal detector  
12:22 Metal piece found by metal detector  
12:23 Advance white stick to 325cm  
12:27 Metal piece found by metal detector  
12:30 Metal piece found by metal detector  
12:33 Metal piece found by metal detector  
12:34 Advance white stick to 305cm  
12:35 Metal piece found by metal detector  
Metal piece found by metal detector  
12:36 Metal piece found by metal detector  
12:45 Metal piece found by metal detector  
12:45 Work stops

Paulino's calculations: 183 minutes worked (excluding QA). [234 minutes were worked including QA]

In Lane 3, 175cm was completed; in Lane 4, 400cm were completed

Manual demining systems – comparative trials: Mozambique 2004.

Total at end of day 2 = 5.75 square metres.

Mines found: Lane 3 = 2 x T72, 1 x GYATA; Lane 4 = 2 x T72, 2 x GYATA

Total metal found in day = 40 (8 in lane 3, 32 in Lane 4)

Quantity of water used, 2 litres approx.

### **Trial 1, Lanes 3 and 4, 4<sup>th</sup> November**

**Monitor:** Paulino Gove

**Deminer:** Helder Martins

**Section Commander:** Fernando Laice

06:51 Start [at 400cm in Lane 4]

06:52 Advance white stick to 445cm

06:53 Fragment located

07:03 Fragment located

07:05 Advance white stick to 465cm

07:06 Fragment located by eye

07:08 Deminer does a detector check over all of Lane 4

07:16 Deminer finishes Lane 4

07:17 Section Commander starts QA of Lane 4

07:20 Stop for rest break [Section Commander continues]

07:20 Section Commander finishes QA check

Paulino's calculations:

25 minutes worked; 1 square metre cleared: No mine found: 4 fragments found: 5 litres of water used.

[29 minutes were worked including QA.]

## **Trial 2: magnetic trowel**

Two deminers worked on two five metre lanes each. Target mines were concealed at random positions, eight in each deminer's area. The Minelab metal detector was used to locate indications of metal in the ground.

Four mine surrogates were missed. One of the discovered mines were only located during QA.

### **Trial 2, lanes 1 and 2, 2<sup>nd</sup> November 2004, ADP Team 2**

**Monitor:** Mate Gaal

**Deminer:** Januario Justino Mindo

**Section Commander:** Dionisio Chaka

6 mines were located by the deminer during this trial. Ten metres were cleared in 188 minutes (including QA), at a nominal average advance of a metre in every 19 minutes.

On removing the latex top of the discovered targets, light corner damage (wood exposed) was found on the top corner of a GYATA and evidence of a lateral strike across the top of one Type 72 was apparent (wood dented, latex torn).

Two mines were missed (Type 72, buried at 12cm to top).

07:11 Start work

07:15 5 magnetic fragments found

07:17 Magnetic fragment found

2 magnetic fragments found

1 non-magnetic fragment found

07:20 1m

07:23 Fragment located

07:28 Advance white stick to 145cm

07:31 **MINE** located (160,20), 1cm depth. Type 72 [lateral strike across top, denting wood to depth of less than 1mm: AVS confirmed, probably done with sharp edge of trowel]

07:33 Work resumed after mine removed

07:35 Advance white stick to 190cm

07:39 Advance white stick to 245cm

07:41 Stop for rest break

Section Commander does QA and find two small fragments

.....

08:02 Work starts

Deminer started again from the start of the lane, found a few fragments

08:09 Reached the White stick at 245cm

08:19 Cutting grass with shears ahead of white stick

08:20 Pinpointing detector reading

08:21 Uses secateurs; Prods, finds fragment

08:23 Works behind white stick, pinpoints, trowels

08:26 Ignores a weak signal and returns to working ahead of white stick

Advances white stick to 310cm

08:28 Uses shears

08:29 Pinpoints reading

08:31 Stops for rest break

.....

Between 08:02 and 08:31 a fragment was found outside the lane and put into the bucket.

08:51 Restart work

Checks behind white stick

08:52 Works ahead of white stick

09:02 Asks Section Commander for water

09:05 Empties bucket on place of investigation

09:06 Three fragments on surface located with magnet

09:14 Asks for more water, continues digging

09:16 Empties half bucket, waits for water to soak in

09:20 **MINE** located, 335,80, GYATA, light corner damage (photographed and videoed) [AVS: confirmed]

Stop for rest break

.....

09:44 Start work

09:45 Advance white stick to 340cm

09:51 Advance white stick to 4m

09:53 Moved white stick back to 3.4m

09:54 Advance white stick to 4m

09:58 Pours ¼ bucket of water onto investigation area

10:02 Pours the rest of the bucket onto area (2<sup>nd</sup> bucket today)

10:05 **MINE** discovered at 440,.0, a GYATA at 1cm [no damage: AVS: confirmed]

10:07 Work resumes after mine removed

10:09 Advance white stick to 4.5m

10:10 Stop for rest break

.....

11:00 Start work

11:06 Finished five metre lane.

Checks lane with detector from start to finish.

Finds one fragment

11:08 Starts lane 2

Locates fragment outside of lane

11:14 Advances white stick to 55cm

11:19 Pours ½ bucket of water onto investigation

11:23 **MINE** discovered, (70,40), Type 72 [AVS: no damage to top of mine]

11:24 Work resumes after mine removed

11:28 Advances white stick to 115cm

11:29 Stops for rest break  
.....  
11:50 Starts work  
      Detects behind the white stick  
11:54 Advances white stick to 155cm  
11:55 Advances white stick to 200cm  
11:58 ¼ bucket (emptied 3<sup>rd</sup> bucket)  
11:59 **MINE** located (230,10), GYATA at 1cm [no damage: AVS: confirmed]  
12:02 Work resumes after mine removed  
12:03 White stick to 235m  
12:04 Fragment located outside of lane  
12:06 Advanced white stick to 290cm  
12:09 Advanced white stick to 325cm  
12:10 Works behind white stick in presence  
12:11 Works ahead of white stick  
12:14 Advanced white stick to 385cm  
12:16 ¾ bucket  
12:19 Stops for rest break  
      Section Commander starts QA from end of lane [AVS: Lane 1?]  
12:23 Finishes QA.  
.....  
12:41 Starts work  
12:44 **MINE** discovered (410,80) GYATA at 12cm [no damage: AVS: confirmed]  
12:46 Work continues after mine removed  
12:48 Checks behind white stick.  
12:49 Finishes Lane 2.  
12:51 Section Commander does QA, starting from \*\*\*\* (“backwards”)  
12:53 Trial finished.

64 fragments were found with a magnet, 6 ferrous fragments were found without the magnet and 2 non ferrous fragments. The total fragments were 72. [Two fragments were found outside of the lanes so should be discounted.] Total mines found by the deminer were 6, and two were missed. The items found, (76), give a density of 7.6 in each metre over ten metres.

The missed mines were Type 72 AP surrogates buried at a depth of 12cm to the top.

## **Trial 2, Lanes 3 and 4**, 2nd November 2004, ADP Team 2

**Monitor:** Paulino Tule Gove

**Deminer:** Julio Ernesto Wache

**Section Commander:** Dionisio Chaka

The trial included the use of a Minelab metal detector.

5 mines were located by the deminer during this trial. A further mine was located by the QA. Ten metres were cleared in 344 minutes (including QA) over two days, at a nominal average advance of a metre in every 34 minutes.

On removing the latex top of the discovered targets, no tool damage was found on the top of them.

Two mines were missed (one GYATA and one Type 72, buried at 12cm to the top).

07:11 Start work

07:25 Fragment found with Magnet

07:26 Three fragments found with magnet

07:28 Advance white stick to 20cm

07:42 Stop for rest break

.....

08:01 Restart work

08:11 Used the prodder vertically

08:12 Metal found using metal detector

White stick moved to 65cm

08:14 White stick moved back to 45cm

08:23 Fragment found with Magnet

Advance white stick to 90cm

08:25 Advance white stick to 1m

08:26 One square metre completed

08:28 Fragment found with Magnet (and put in wrong bucket)

08:29 Move white stick back to 80cm

08:30 Move white stick back to 75cm

08:31 Stop for rest break

.....

08:51 Restart work

08:53 Move white stick back to 60cm

08:59 Metal piece found with detector, non-magnetic

09:02 White stick advanced to 1m

09:04 Fragment found with Magnet

09:09 Stop to use kneeling protection (knee-pads)

09:10 Start again

09:11 **MINE** discovered at 130cm, Type 72. Top was not damaged. [AVS: confirmed]

09:12 Mine removed and trial proceeds.

09:13 Advance white stick to 140cm

09:15 Fragment found with Magnet  
09:17 Fragment found with Magnet  
09:19 Advance white stick to 190cm  
09:20 Advance white stick to 2m  
Fragment found with Magnet  
09:21 Fragment found with Magnet  
Stop for rest break.  
.....  
09:41 Work resumes  
09:43 Self preparation  
09:44 Fragment found with Magnet  
09:45 Fragment found with Magnet  
09:46 Advanced white stick to 2.3m  
09:47 Fragment found with Magnet  
09:50 Advanced white stick to 2.7m  
09:52 4 Fragments found with Magnet  
One detector reading ignored at 2m x 98cm  
10:04 Fragment found with Magnet  
10:05 Advanced white stick to 3.3m  
10:07 Deminer is searching behind white stick  
10:08 Fragment found with Magnet  
10:10 Advanced white stick to 3.5m  
Fragment found with Magnet  
10:11 Stop for breakfast break.  
.....  
11:00 Restart work  
11:01 Fragment found with Magnet  
11:05 Advanced white stick to 3.6m  
11:07 Fragment found with Magnet  
11:10 Advanced white stick to 4m  
11:11 Fragment found with Magnet  
11:14 Advance white stick to 4.4m  
4 Fragments found with Magnet  
11:15 deminer ignored metal detector reading  
11:24 fragment found  
11:29 Stop for rest break  
Section Commander searches area during rest period.  
11:45 **MINE** discovered, missed GYATA at 3m. Top has light corner damage.  
[AVS: confirmed]  
11:47 Section Commander completes QA and goes to rest area

.....

- 11:49 Restart work
- 11:50 Deminer is using the wrong trowel
- 11:53 Deminer is using the right trowel
- 11:56 **MINE**, GYATA discovered, no damage to top. [AVS Confirmed] Deminer was clearing to a depth less than 13cm.
- 11:57 Advance white stick to 4.5m
- 11:58 Fragment found with Magnet
- 11:59 Advance white stick to 4.6m
- 12:00 Finishes Lane 3 (5 metres)
- 12:02 Moved white stick back to 4.5m
- 12:05 Makes excavation badly. Always rushing.
- 12:15 Finishes lane 3.
- 12:17 Starts on Lane 4
- 12:19 Stop for rest break

.....

- 12:39 Restart work
- 12:42 Fragment found with Magnet
- 12:44 Fragment found with Magnet
- 12:46 Fragment found with Magnet
- 12:51 Fragment found with Magnet
- 12:55 Fragment found with Magnet
- 13:09 Work stops

Two mines were located by the deminer, one Type 72 and one GYATA. A further GYATA was discovered by the Section Commander during internal QA.

45 fragments were found, of which one was found by eye and one fragment was non-magnetic.

Five fragments were found in advance of the white stick (in Lane 4) so they should be removed from the calculation for the fragment density of the cleared area.

There were 8 fragments to the square metre.

Add the three mine targets to the fragment total and there were 43 indications in 5 metres, so 8.6 indications to the square metre.

## **Trial 2, Lanes 3 and 4, 3<sup>rd</sup> November 2004, ADP Team 2**

**Monitor:** Neville Goulton

**Deminer:** Julio Ernesto Wache

**Section Commander:** Dionisio Chaka

- 06:47 Start work (Lane 4)  
Red stick to 0.5m
- 06:55 **MINE** located, Type 72 at 0.4, 0.3, no damage [AVS: confirmed]
- 06:57 Work restarts after mine is removed

06:58 Advance white stick to 0.3m  
Advance red stick to 0.7m

06:59 Detection  
Locate fragment on surface with magnet, 0.4 x 0.9

07:00 Detection

07:01 Locate fragment on surface with magnet, 0.6 x 0.7  
Detection  
Locate fragment on surface, non-magnetic 0.6 x 0.7

07:02 Detection

07:03 Advance white stick to 0.5m  
Advance red stick to 1.2m

07:04 Locate fragment on surface with magnet, 0.7 x 0.3

07:05 Advance white stick to 1.2m  
Advance red stick to 1.6m

07:06 Detection, 1.4, 0.9

07:08 Locate fragment of surface with magnet, 1.5 x 0.7

07:09 Add water

07:12 Add water

07:15 Locate fragment, magnetic, deep 1.5 x 0.9

07:16 Detection 1.3 x 0.3

07:17 Stop for rest break, water added to search area  
.....

07:39 Restart work

07:44 **MINE** located. Type 72, 1.3 x 0.3, no damage to top, prodder strikes on side. [AVS: confirmed]

07:46 Work continues after mine removed

07:47 Detection, 1.5 x 0.2

07:53 Find fragment, magnetic, 1.3 x 0.5  
Detection 1.6 x 0.8

07:55 – 07:58 Detector problem. \*\*\*\*\* to recalibrate

07:58 Advance white stick to 1.6m  
Advance red stick to 2m

07:59 Detection 1.7 x 0.1

08:01 Locate fragment, magnetic at 1.7 x 0.1  
Detection 2.0 x 0.9

08:02 Locate fragment at 2.1 x 0.9

08:03 Apply water. Trowel is muddy. Bangs mud off, magnet comes off

08:07 Stop for rest break  
.....

08:28 Start work

08:31 **MINE** found, GYATA, no damage, [AVS: confirmed] 2.0 x 0.9

- 08:32 Work continues after mines has been removed
- 08:33 Advance white stick to 1.9m  
Advance red stick to 2.2m  
Advance white stick to 2.2m  
Advance red stick to 2.7m
- 08:34 Detection, 2.2 x 0.3
- 08:36 Locate fragment, magnetic, 2.2 x 0.3
- 08:37 Detection 2.3 x 0.1
- 08:38 Locate fragment, magnetic, 2.3 x 0.1
- 08:44 Apply water
- 08:47 Locate fragment, magnetic, 2.5 x 0
- 08:48 Locate fragment, magnetic, 2.8 x 0.1
- 08:49 Locate fragment, magnetic, 2.8 x 0.1
- 08:51 Detection, 2.8 x 0.1
- 08:52 Locate fragment, magnetic, 2.8 x 0.1
- 08:53 Advance white stick to 2.4  
Advance red stick to 2.9
- 08:55 Locate fragment, magnetic, 2.7, 0.2
- 08:56 Locate fragment, magnetic, 2.8 x 0.3  
Stop for rest break.  
QA check takes place
- .....
- 09:18 Work starts
- 09:19 Advance white stick to 3m  
Advance red stick to 3.6m  
Locate fragment, magnetic, 3.5 x 0.8
- 09:20 Locate fragment, magnetic, 3.2 x 0.8
- 09:21 Locate fragment, magnetic, 3.6 x 0.5  
Advance white stick to 3.4m  
Advance red stick to 4m
- 09:22 Locate fragment, magnetic, 3.7 x 0.7  
Locate fragment, magnetic, 3.8 x 0.7
- 09:23 Locate fragment, magnetic, 3.9 x 0.9
- 09:25 Locate fragment, magnetic, 3.9 x 0.7
- 09:26 Detection, 3.9 x 0.5
- 09:26 Apply water
- 09:33 Locate fragment, magnetic, 3.9 x 0.4
- 09:34 Advance white stick to 3.9m  
Advance red stick to 4.4m  
Locate fragment, magnetic, 3.9 x 0.1

Manual demining systems – comparative trials: Mozambique 2004.

09:35 Locate fragment, magnetic, 4.3 x 0.2  
09:36 Locate fragment, magnetic, 4.3 x 0.8  
09:40 Advance white stick to 4.4m  
Advance red stick to 5m  
09:40 Locate fragment, magnetic, 4.7 x 0.1  
Advance white stick to 5m  
09:42 End of deminer work  
09:46 QA check found a magnetic fragment at 4.7 x 0.1  
09:48 QA check ended

In one hour and 56 minutes of work, the deminer covered 5m [the whole of lane 4]. Advance was at a rate of approximately 2.5m per hour.

Fragments found: 35 magnetic, one non-magnetic.

Mines found: 1 GYATA, 2 Type 72

The total of mines and fragments was 38 over 5 metres, giving an average of 7.6 per square metre.

### Trial 3: magnetic brush-rake

Two deminers (Team 2) worked on two five metre lanes each. Target mines were concealed at random positions, eight in each deminer's area. The trial included the use of a MineLab metal-detector.

#### Trial 3, Lanes 1 and 2, November 3<sup>rd</sup>: ADP Team 2

**Monitor:** Mate Gaal

**Deminer:** Januario Justino Mindo

**Section Commander:** Dionisio Chaka

Six mines were located by the deminer during this trial. A further mine was located during the integral QA. Ten metres were cleared by deminer and QA in 177 minutes, at a nominal average advance of a metre in every 18 minutes.

The discovery of fragments with or without the magnet was not accurately recorded, and the total number of fragments not counted. The same number of fragments were placed as in lanes 3 and 4, so the record for lane 3 and 4 is copied here: over the ten metres, the average fragment/mine density was 7.4 per square metre.

On removing the latex top of the discovered targets, light prod damage was found on the top of one Type 72 and one GYATA. It is considered unlikely that either would have been initiated without greater pressure.

One mine was missed (Type 72, buried at 12cm). A further Type 72 was only located by QA (this was the one with light damage on top).

10:38 Work starts

10:39 Stops to put on his kneepads

10:40 Continues

10:44 Advance white stick to 45cm

10:53 **MINE** located, Type 72 at (70,30) No damage [AVS: Single point penetration found under latex: not considered hard enough to initiate the mine]

10:54 Continues working

10:59 Carries out 2 trowels of soil to find a fragment outside of the lane. Cannot find the fragment, gives up.

11:00 Continues to work in the lane

11:03 Advance white stick to 200cm

11:08 Stop work

.....

11:26 Start work

11:27 Advance white stick to 260cm

11:32 **MINE** located, GYATA at 1cm, 270,80, No damage [AVS: confirmed]

11:33 Continues working

11:35 Advance white stick to 300cm

11:38 Advance white stick to 350cm

11:45 Advance white stick to 390cm

11:47 Advance white stick to 475cm

11:48 Advance white stick to 500cm

Removes sticks and checks whole lane with detector

- 11:53 Ends work, leaves lane 1  
[In lane 1, the deminer used 2 buckets of water]  
Continues in Lane 2
- 11:54 Stops while Section Commander QA's all of Lane 1
- 11:56 Rest break
- .....
- Section Commander finds two fragments
- 12:09 QA finished
- 12:16 Deminer starts work
- 12:18 Advances white stick to 45cm
- 12:27 **MINE** located, (75,40), GYATA at 12cm, Damage to top edge? [AVS: very light if any: unconfirmed]
- 12:29 Continues work after mine removed
- 12:31 Advances white stick to 110cm
- 12:33 Advances white stick to 165cm
- 12:40 Advances white stick to 220cm
- 12:45 **MINE** located, GYATA at 1cm, (260,85) [AVS: no damage]  
Stop work
- 12:47 Advance white stick to 270cm (after stopping)  
Checks the area just cleared (himself)  
Empties the 2<sup>nd</sup> bucket of water in front of the white stick.
- 12:48 Stops work (this time really)

Deminer worked for 90 recorded minutes (excluding QA) and covered 7.7 square metres

Number of fragments found:

1 x GYATA and 1 x Type 72 were found in Lane 1

### **Trial 3, Lanes 1 and 2, 4<sup>th</sup> November, ADP Team 2**

**Monitor:** Manuel Django

**Deminer:** Januario Justino Mindo

**Section Commander:** Chaka

- 06:51 Start
- 06:54 Fragment found 310 x 50cm, rake not used
- 06:55 Fragment found 310 x 40cm, rake not used
- 06:56 Fragment found 340 x 50cm, rake not used
- 06:57 Advance white stick to 310cm, water used
- 07:05 Fragment found 350 x 50, rake not used
- 07:09 Fragment found 355 x 40cm, using brush rake
- 07:10 Advance white stick to 355cm

07:11 Two fragments found 380 x 50, rake not used  
07:12 Fragment found 390 x 30cm, using brush rake  
07:14 Fragment found 395 x 40cm, using brush rake  
07:15 Fragment found 400 x 20cm, rake not used  
07:17 Fragment found 450 x 90cm, using brush rake  
07:21 Stop for rest break  
.....  
07:40 Restart work  
07:45 **MINE** found at 415 x 60cm, GYATA at 12cm, no damage [AVS: no damage: confirmed]  
07:48 Advance white stick to 380cm  
07:52 Advance white stick to 420cm, water used  
07:56 **MINE** found, 470 x 30cm, Type 72 at 1cm, no damage [AVS: no damage: confirmed]  
07:58 Lane 2 completed.  
Section Commander starts QA of entire 10 metres  
08:09 **MINE** Section Commander locates Type 72 at 150 x 5cm, [AVS: no damage: confirmed]  
08:24 Section Commander's QA is completed

48 minutes were worked by the deminer (excluding QA). A further 26 minutes were spent by the Section Commander performing QA of the area.

4 fragments were found with the rake

8 fragments were found without the rake

1 fragment was not magnetic

2 buckets of water were used.

1 x GYATA and 1 x Type 72 were found in Lane 1

3 x GYATA and 2 x Type 72 were found in Lane 4

1 x Type 72 was missed. One Type 72 was missed by the deminer but found during QA.

### **Trial 3, Lanes 3 and 4, 3<sup>rd</sup> November, ADP Team 2**

**Monitor:** Neville Goulton

**Deminer:** Julio Ernesto Wache

**Section Commander:** Dionisio Chaka

All 8 mines were located by the deminer during this trial. Ten metres were cleared in 221 minutes, at a nominal average advance of a metre in every 22 minutes. Over the ten metres, the average fragment/mine density was 7.4 per square metre. 88% of the fragments were found using the magnet Brush-rake.

On removing the latex top of the targets, light prod damage (penetrating latex and paint and exposing wood) was found on the top of one GYATA and one TYPE 72. It was not thought likely that the damage would have initiated a real device.

10:36 Start

Change batteries in detector

10:42 Restart: red and white sticks at start line

10:45 Fragment located with rake magnet (red stick in way of brush-rake)

- 10:45 Fragment located with rake magnet
- 10:47 Fragment located with rake magnet
- 10:48 Advance red stick to 0.9m  
Detection at 0.3 x 0.7
- 10:49 Apply water  
Excavation
- 10:52 Locate fragment x 2, magnetic  
Detector scan
- 10:53 Advance white stick to 0.9m
- 10:54 Fragment located with rake magnet
- 10:55 Fragment located with rake magnet  
Fragment located with rake magnet
- 10:57 Advance red stick to 1.6m
- 10:58 Detection at 1.5 x 0.8
- 10:59 Apply water  
Excavation
- 11:04 Fragment located 1.5 x 0.8, magnetic
- 11:05 Fragment located 1.5 x 0.8, by raking spoil from excavation with magnet  
Detector scan
- 11:06 Advance white stick to 1.7m
- 11:07 Fragment located with rake magnet  
Fragment located with rake magnet
- 11:09 Advance red stick to 2.2m
- 11:10 Detection at 2.2m  
Apply water  
Stop for rest break
- .....
- 11:28 Restart work
- 11:31 Fragment located, magnetic
- 11:32 Advance white stick to 2.0m  
Advance red stick to 2.5m
- 11:34 Detection at 2.1 x 0.8  
Apply water
- 11:41 **MINE** located at 2.0 x 0.8, Type 72, no damage [AVS: single prod onto top of mine revealed after latex removal: very light: not considered likely to have initiated this mine.]  
[Visible signs of raking not same as magnet coverage!]  
Detector scan
- 11:43 Advance white stick to 2.4m  
Fragment located with rake magnet
- 11:45 Fragment located with rake magnet

- 11:46 Fragment located with rake magnet
- 11:47 Advance red stick to 3.1m
- 11:49 Detection at 2.5 x 0.3m  
Water applied
- 11:55 **MINE** located at 2.5 x 0.3, Type 72, possible probe strike on top [AVS: Single prod strike confirmed on removal of latex: very light: unlikely to have initiated the mine.]
- 11:57 Stop for rest break
- .....
- 12:19 Restart work  
Detector scan
- 12:20 Locate fragment at 2.9 x 0.5, magnetic
- 12:21 Advance white stick to 3m
- 12:22 Fragment located with rake magnet
- 12:23 Fragment (x 2) located with rake magnet
- 12:25 Fragment located at .8 x 0.3, magnetic  
Detector scan
- 12:26 Advance white stick to 3.3m  
Advance red stick to 4m  
Detection at 3.9 x 0m  
Excavation
- 12:30 **MINE** located at 3.9 x 0m, GYATA, damage to top edge [AVS: very light if there: unconfirmed.]  
Detection
- 12:32 Advance white stick to 4m  
Fragment located with rake magnet
- 12:33 Fragment located with rake magnet
- 12:34 Fragment located with rake magnet  
Fragment located with rake magnet  
Fragment located with rake magnet
- 12:36 Advance white stick to 4.3m  
Advance red stick to 5m  
Detector scan  
Excavation
- 12:37 Locate fragment 4.8 x 0.8, magnetic
- 12:38 Locate fragment 4.7 x 0.8, magnetic
- 12:40 **MINE** located at 4.8 x 0.8, GYATA, hit on top edge and side puncture [AVS: very light top edge damage, uncertain: unconfirmed.]
- 12:43 Detection at 4.8 x 1
- 12:44 Fragment located at 4.8 x 1
- 12:45 Finish Lane 3
- [Operator noticeably less careful doing the excavations towards the end of the lane.]

- 12:46 Starts lane 4
  - Detector scan [both sticks at start line]
- 12:47 Fragment located with rake magnet
  - Stop work

Worked for 91 minutes (excluding mine removal time-out)

25 fragments were found using the rake

5 fragments were found without using the rake.

2 x Type 72 and 2 x GYATAs were found in Lane 3

### **Trial 3, lanes 3 and 4, 4<sup>th</sup> November, ADP Team 2**

**Monitor:** Neville Goulton

**Deminer:** Julio Ernesto Wache

**Section Commander:** Dionisio Chaka

- 06:54 Work starts
  - Detector scan
- 06:56 Fragment located with rake magnet
- 06:57 Fragment located with rake magnet
- 06:58 Advance red stick to 0.6m
  - Detector scan
- 07:01 Advance white stick to 0.6m
  - Advance red stick to 1.0m
- 07:02 Detection at 0.7 x 0.5
  - Apply water
  - Excavate
- 07:10 **MINE** located at 0.7 x 0.5, GYATA, no sign of damage [AVS: confirmed]
- 07:11 Restart after mine removal
- 07:13 Fragment located at 0.4 x 0.9, magnetic
- 07:16 Change detector batteries
- 07:21 Restart work
- 07:22 Advance white stick to 0.7m
  - Advance red stick to 1.2m
  - Fragment located with rake magnet
- 07:23 Stop for rest break
- .....
- 07:44 Restart work
  - Detector scan
  - Advance white stick top 1.2m
- 07:45 Fragment located with rake magnet

07:46 Fragment (x 3) located with rake magnet  
Fragment (x 2) located with rake magnet

07:50 Advance white stick to 1.9m  
Advance red stick to 1.9m  
Fragment located with rake magnet

07:51 Fragment located with rake magnet

07:52 Advance red stick to 2.4m  
Detection at 2.1 x 0.8

07:53 Locate fragment at 2.1 x 0.8, non magnetic

07:55 Detection at 2.1 x 1.0  
Apply water, Excavation

07:58 Apply water

08:00 **MINE** located at 2.1 x 1.0, Type 72, no damage [AVS: confirmed]

08:01 Restart work after mine removal  
Detector scan

08:03 Advance white stick to 2.4m

08:04 Fragment located with rake magnet

08:05 Fragment located with rake magnet

08:06 Fragment located with rake magnet  
Fragment located with rake magnet

08:08 Advance red stick to 2.9m  
Detection at 2.4 x 0.2

08:12 Stop for rest break  
.....

08:34 Start work  
Apply water

08:36 **MINE** locates at 2.4 x 0.3, Type 72, no damage [AVS: confirmed]

08:37 Restart work after mine removed  
Detector scan

08:40 Advance white stick to 2.9m

08:41 Fragment located with rake magnet  
Fragment located with rake magnet  
Fragment located with rake magnet  
Fragment located with rake magnet

08:45 Detection at 2.8 x 0.1  
Apply water, Excavate

08:58 Move on – nothing found

08:59 Advance white stick to 3m, Advance red stick to 3.5m

09:00 Detection at 3.3 x 0.1  
Apply water

- 09:03 Stop for rest break  
Fragment located at 3.3 x 0.1, magnetic  
.....
- 09:24 Restart work
- 09:26 Advance white stick to 3.5m
- 09:27 Fragment located with rake magnet  
Fragment located with rake magnet  
Fragment located with rake magnet  
Fragment located with rake magnet
- 09:30 Advance red stick to 4.0m
- 09:31 Detection at 3.7 x 0.9, Apply water
- 09:35 Fragment located at 3.7 x 0.9, magnetic
- 09:36 Advance white stick to 4.0m
- 09:38 Detection at 4.2 x 0.7  
Apply water, Excavate
- 09:41 **MINE** located, GYATA, no damage [AVS: confirmed]
- 09:41 Restart work after mine removed
- 09:42 Advance white stick to 4.3m  
Advance red stick to 4.3m
- 09:43 Fragment located with rake magnet
- 09:44 Fragment located with rake magnet
- 09:45 Fragment located with rake magnet
- 09:47 Fragment located with rake magnet
- 09:48 Detection at 4.9 x 0.6  
Apply water
- 09:52 Stop for rest break  
.....
- 10:43 Start QA of entire Lane 4
- 10:58 Section Commander finds fragment at 4.9 x 0.6 using rake magnet
- 10:59 Clearance ends

114 minutes worked (including mine removal time-out, to be removed later)

The magnet rake found 33 fragments: 2 magnetic items were found without the rake: There was 1 additional non-magnetic item.

2 x GYATA and 2 x Type 72 mines were located in Lane 4.

#### **Trial 4: metal detector reliability test**

In the 10 metre test area (comprising two five metre long lanes), 8 targets had been concealed, four Type-72 surrogates and 4 GYATA surrogates. "Natural" fragment contamination was removed from

the surface, but not from sub-surface sources. No fragments were deliberately added. The Minelab F1A4 metal detector was used in this trial, as was the magnet-trowel.

Notes provided by Mate Gaal.

Monitored by Christina Mueller, Mate Gaal and Manuel Raul Django

(The results of the reliability test – markers only, no investigation of signals – are in a separate document.)

#### **Trial 4, Lanes 1 and 2, 5<sup>th</sup> November, ADP Team 2**

All mine surrogates were found: 7 were located by the deminer, with the 8<sup>th</sup> located during the QA process.

Damage likely to have caused an initiation of a real mine was found on one GYATA and damage that would almost certainly have initiated a Type 72 was found on one Type 72. Four other mines were damaged, and the record shows that one of these could have detonated (making three in all).

The 10 metre area was cleared in 207 minutes, giving a nominal advance rate of a metre every 21 minutes.

**Monitor:** Manuel Raul Django, Mate Gaal

**Deminer:** Julio Ernesto Wache

**Section Commander:** Dionisio Chaka

09:10 Start work

09:22 investigation at -12, 32

09:33 **MINE** located at 50, 85, GYATA, no damage [AVS: confirmed]

09:39 advance white stick to 65 cm

09:40 advance white stick to 135 cm

09:41 stop for break

.....

10:51 start work

11:00 advance white stick to 180 cm

11:04 advance white stick to 245 cm

11:05 advance white stick to 295 cm

11:09 **MINE** located at 340, 80, Type 72, no damage [AVS: two 2mm deep punctures found after removal of latex top: possible initiation]

11:12 advance white stick to 360 cm

11:15 advance white stick to 440 cm

11:18 fragment found at 485, 99

11:20 **MINE** located, GYATA at 455, 05, no damage [AVS: severe impact strike one centimetre from edge of mine was found after removing latex top: this mine would probably have been initiated.]

11:21 stop for break

.....

11:41 start work

11:43 lane 1 finished, deminer rechecking the lane

11:48 fragment at 395, 05

11:52 start lane 2  
11:55 fragment at 10, 50  
11:58 advance white stick to 50 cm  
12:01 stop – end of the day

4 fragments found, all with a magnet  
3 mines found, 2 GYATAs and one Type 72  
2 buckets of water used

#### **Trial 4, Lanes 1 and 2, 8th November 2004, ADP Team 1**

**Monitor:** Paulino Tule Gove

**Deminer:** Julio Ernesto Wache

**Section Commander:** Dionisio Chaka

07:00 start work  
07:01 investigation  
07:08 **MINE** found, Type 72 at 40cm; heavily damaged on top [AVS: confirmed, heavy chopping on top of mine would almost certainly have caused an initiation.]  
07:09 detector problem  
07:14 problem solved  
07:15 advance white stick to 95cm  
07:16 investigation  
07:19 0.5 L of water used  
07:21 fragment found with magnet 100cm  
07:22 advance white stick to 145cm  
07:24 investigation  
07:25 1L of water used  
07:30 **MINE** found, Type 72 at 160cm, damaged, two strikes on top [AVS Confirmed: two 1mm deep dents in the top of the mine were found on removal of the latex. Uncertain over whether enough pressure was used to cause an initiation.]  
07:30 stop for break  
.....  
07:35 QA Section Commander finds one metal fragment with magnet in lane 1  
.....  
07:50 restart work  
07:53 advance white stick to 190cm  
07:54 investigation, 1L of water used  
08:00 **MINE** found, GYATA at 225, 15, no damage [AVS: damage exposing wood near top edge found on removal of latex: this could have caused an initiation, but that is uncertain].  
08:01 investigation, 1L of water used  
08:02 advance white stick to 205cm  
08:11 **MINE** found, GYATA at 240, 65, no damage [AVS: confirmed].

08:16 fragment found with magnet, at 240, 66

08:17 advance white stick to 270cm

08:22 stop for break

.....

08:43 start work

**Monitor:** Mate Gaal

08:49 advance white stick to 325cm

08:53 advance white stick to 380cm

08:59 advance white stick to 395cm

09:02,5 finish the lane, check the whole lane

09:08 a bucket of water

09:14 finish the lane

stop for break

.....

09:30 start: QA Section Commander

09:36 **MINE** found, Lane 1, Type 72 at 12cm depth, at 215, 70 [AVS: no damage: confirmed.]

09:38 continues work

09:42 QA of lane 2

09:48 finished

.....

Deminer found: 1 fragment without magnet, 6 fragments with magnet; 4 mines: 2 Type 72, 2 GYATAS.  
QA found: No metal fragments; Mine Type 72 in lane 1 at 215,79 at 12cm depth. 2 buckets of water used

#### **Trial 4, Lanes 3 and 4, 5th November, ADP Team 2**

**Monitor:** Mate Gaal

**Deminer:** Januario Justino Mindo

**Section Commander:** Dionisio Chaka

The ten metre area was cleared and QA checked in 195 minutes, so giving a nominal advance rate of one metre every 19.5 minutes. All 8 surrogate mines were found, one during the integral QA. 15 fragments were found, (10 using a magnet clip on the trowel), so the signal density was 2.3 indications per square metre. Three surrogate mines showed some damage, but none to the extent that an initiation was deemed probable.

09:12 start work

remark: deminer uses two trowels, one with magnet, one without

09:32 bucket of water

09:35 **MINE** found, GYATA at 12cm depth, at 40, 5, no damage [AVS: confirmed]

09:38,5 continues work

09:40 stop for break

.....

10:50 start work

10:58 fragment 50, 50

advance white stick to 75 cm  
10:59 advance white stick to 110 cm  
fragment found at 120, 80  
11:04 **MINE** found, Type 72 1cm depth, at 150, 60, no damage [AVS: confirmed]  
11:04 continued work  
11:05 advance white stick to 200cm  
11:18 **MINE** found, Type 72 at 12 cm depth, at 210, 70, no damage: [AVS: three 2mm deep prod marks in centre of top surface found on latex removal: uncertain whether enough force was applied to detonate the mine.]  
11:19 continue work, advance white stick to 240cm  
11:20 stop for break  
.....  
11:41 start work  
11:43 detector problem (no contact?)  
11:45 problem solved, continues work, advance white stick to 320cm  
11:46 advance white stick to 360cm  
11:46 **MINE** found, GYATA at 1cm depth, at 380, 75, no damage [AVS: confirmed]  
11:47 continue  
11:49 advance white stick to 400cm  
11:50 advance white stick to 430cm  
11:55 **MINE** found, GYATA at 1cm depth, at 460, 30, no damage [AVS: confirmed]  
11:57 finished lane 3  
11:58 check lane 3, investigate 420, 110, decide to ignore the signal, find fragment at 200, 50  
12:02 stop for break, lane 3 finished  
Fragments found: 4 without magnet, 5 with magnet. All fragments were ferrous.  
Mines found: 3 GYATAs; 2 Type 72

#### **Trial 4, Lanes 3 and 4, 8th November 2004**

**Monitor:** Mate Gaal

**Deminer:** Januario Justino Mindo

**Section Commander:** Dionisio Chaka

07:00 start (lane 4)  
07:14 advance white stick to 70cm  
07:15 advance white stick to 100cm  
07:24 advance white stick to 170cm  
07:25 **MINE** found, Type 72 at 210, 98, at 1cm depth, no damage [AVS: two abrasions found under latex, disrupting the surface of the wood: it is considered unlikely that this would have initiated a Type 72 because they were at the side of the belville spring pressure-plate.]  
07:25 continue

07:30 advance white stick to 230cm  
stop for break

.....

07:51 start work

07:58 advance white stick to 310cm  
check the whole lane between 0 cm and 310 cm

08:00 continue work ahead of 310 cm

08:01 advance white stick to 350cm

08:09 **MINE** found, GYATA at 12cm depth, at 380, 30, no damage [AVS: single prod penetration on the top of the mine found after latex removal: 1mm. It is thought unlikely that this would have initiated a real mine.]

08:13 continue work

08:15 advance white stick to 415cm

08:20 remove sticks  
check the whole lane

08:21 finish the lane

.....

08:22 QA Section Commander lane 3

08:30 QA Section Commander lane 4

08:37 **MINE** found, Type 72 at 12cm depth, at 60, 80, no damage [AVS: confirmed]

08:37 continue

08:51 fragment found with MD at 145, 10

09:18 finish QA

.....

Fragments found by deminer: With magnet: 5; without magnet: 0

Fragments found by QA: with magnet: 0; without magnet: 1 (ferrous)

Mines found by deminer: 1 GYATA, 1 Type 72

Mines found by QA: 1 Type 72

## **Trial 5: REDS rake system**

The ADP deminers and Section Commanders were training by Jan Eric Stoa (NPA Sri Lanka) in the REDS system. Training was constrained by limited equipment (only one set of rakes) and limited to one day.

The start of the trial was delayed by the late arrival of rake heads from Sri Lanka. The ADP deminers and Section Commander were selected by the system from all the deminers and both Section Commanders. The result was a combination of the old ADP Teams 1 and 2, so is referred to as ADP Team 3.

The trial started using one Harrow rake head brought by AVS and locally purchased Brush rakes. The rakes were finally cleared from Mozambique customs on 17<sup>th</sup> November and arrived at the test area at 11:45. Clearance of lanes 3 and 4 began during the last session of that day.

### **Trial 5, Lanes 1 and 2: 16<sup>th</sup> November, ADP Team 3**

**Monitor:** Mate Gaal, Paulino Gove

**Deminer:** Carlos Tembe

**Section Commander:** Fernando Laice

Deminer cleared 5.12 square metres in (nominal) 630 minutes, so achieving an advance of a metre in every 123 minutes. In fact, the lane width (to bottom of side trenches was a measured 12cm wider at full clearance depth. This means that the deminer cleared an area 512 x 112cms, or 5.7344 square metres. The clearance rate was then approximately a metre in 110 minutes.

The deminer found all mines in the area cleared, a total of five. Of these, two were unmarked. Three were found to have light dents in the top when the latex was removed. The damage were not thought likely to have caused an initiation.

06:46 Start [no whistle]

Deminer digs the area in front of the start line of Lane 1

06:52 Deminer starts to work in lane with Brush rake

06:54 Uses Harrow rake

06:59 Uses Brush rake

07:03 Uses Harrow rake

07:09 Uses Brush rake

07:14 Uses Harrow rake

07:19 Whistle for rest break

.....

[Monitoring is taken over by Paulino Gove]

07:35 Whistle to start work

07:36 Uses Harrow rake

07:41 Uses Brush rake

07:47 Uses Harrow rake

07:52 Stop for working without safety spectacles

07:55 Restart with Heavy rake and safety spectacles

07:56 Uses Brush rake

08:01 Uses Harrow rake

08:03 **MINE** located, (50, 98) using Heavy rake [AVS: Type 72, light dent from rake tines on top, less than 1mm, no paint removed, latex peeled]

08:04 Continue after mine removed  
08:05 Whistle for rest break  
.....  
08:25 Whistle to start work  
08:27 Uses Harrow rake  
08:31 Uses Brush rake  
08:36 Uses Harrow rake  
08:41 Uses Brush rake  
08:43 Uses Harrow rake  
08:45 Uses Brush rake  
08:49 Uses Harrow rake  
08:55 Whistle for rest break  
.....  
09:15 Whistle to start work  
09:16 Uses Harrow rake  
09:18 Uses Brush rake  
09:28 Uses Harrow rake  
09:33 Uses Brush rake  
09:38 Uses Harrow rake  
09:41 Uses Brush rake  
09:43 Uses Harrow rake  
09:45 Uses Brush rake  
Whistle for rest break  
.....  
10:35 Start [no whistle]  
10:38 Uses Brush rake  
10:42 Uses Harrow rake  
10:49 Uses Brush rake  
10:50 First square metre completed  
10:51 Uses Harrow rake  
10:54 Uses Brush rake  
10:57 Uses Harrow rake  
10:58 Uses Brush rake  
11:05 Whistle for rest break  
.....  
11:25 Whistle to start work  
11:27 Uses Brush rake  
11:28 Uses Harrow rake  
11:31 Uses Brush rake, Uses Harrow rake  
11:32 Uses Brush rake

- 11:33 Section commander investigating  
**MINE** located, GYATA, (130, 20) not lifted by rake [AVS: Light dent on top from rake tine – less than 1mm deep, no paint removed, latex peeled]
- 11:36 Deminer continues after mine removal
- 11:38 Uses Brush rake
- 11:42 Uses Harrow rake
- 11:44 Secateurs to cut roots  
Uses Harrow rake
- 11:50 Uses Brush rake
- 11:55 Whistle for rest break
- .....
- 12:10 Whistle to start work
- 12:12 Uses Harrow rake
- 12:14 Uses Brush rake
- 12:15 Uses Harrow rake
- 12:17 Uses Brush rake
- 12:18 **MINE** located, Type 72, (205, 85) exposed by Brush-rake. No obvious damage  
[AVS: shows light denting under rubber, apparently from Heavy rake tines]
- 12:21 Mine removed, deminer continues with Brush rake
- 12:24 Uses Harrow rake
- 12:30 Uses Brush rake
- 12:36 Uses Harrow rake
- 12:37 Uses Brush rake
- 12:40 Preparing to stop work and closing lane (uses marking sticks)
- 12:45 Work stops (no whistle)  
50 litres of water were poured over the lane after work stopped.  
[The Section Commander is monitoring only one person, so does not use his whistle at all times.]

Paulino's calculations: 170 square cms cleared in a day. Two Type 72 and one GYATA were discovered. No water used during work.

[1.7 square metres were cleared in 210 minutes, so giving an average advance rate of a metre every 123.5 minutes.]

### **Trial 5, Lanes 1 and 2:** 17<sup>th</sup> November, ADP Team 3

**Monitor:** Paulino Gove

**Deminer:** Carlos Tembe

**Section Commander:** Fernando Laice

- 06:40 Whistle to start work [Deminer wearing all PPE]  
Adjusts the marking sticks
- 06:41 Uses Brush rake
- 06:44 Changes to the Harrow rake

[Harrow rake is held so that the head is further from the deminer, increasing safety and comfort, as a result of instructions from the REDS instructor.]

06:48 Uses secateurs

06:49 Uses Brush rake

06:55 Uses Harrow rake

07:05 Uses Brush rake

[The area in front of the base-trench is rakes with the Brush rake before the Harrow rake.]

07:09 Whistle for rest break

07:11 Section Commander moves some of the excavated soil behind with a spade

07:12 Section Commander leaves for rest area

.....

07:30 Whistle to start work

07:32 Uses Brush rake

07:34 Uses Harrow rake

07:38 Second square metre completed

07:41 Uses Brush rake

07:50 Uses Harrow rake

08:00 Whistle for rest break

.....

08:20 Whistle to start work

08:22 Deminer uses spade to reduce height of spoil pile, moving it backward

08:24 Uses Brush rake

08:31 Uses Harrow rake

08:43 Uses Brush rake

Uses spade to move processed spoil back in lanes

08:46 Uses Brush rake

08:48 Uses spade to move processed spoil back in lane

08:50 Whistle to stop work

08:51 Section Commander places marker to show QA check on side of lane markings, checks depth and move some processed spoil behind the lane

08:55 QA finished

.....

09:10 Whistle to start work

09:12 Uses Brush rake

09:14 Uses Harrow rake

09:19 **MINE** located, Type 72 exposed by Uses Harrow rake (270, 65), not damaged [AVS: confirmed]

09:20 Continues to use Heavy rake after mine removal

09:23 Uses Brush rake

09:30 Uses Harrow rake

09:40 Whistle for rest break

.....

10:30 Whistle to start work  
10:32 Uses Harrow rake  
10:38 Uses spade to move processed spoil back in lane  
10:41 Uses Brush rake  
10:46 Uses Harrow rake  
10:47 Uses Brush rake  
10:48 Uses Harrow rake  
10:49 Uses Brush rake  
10:54 Uses Harrow rake  
10:55 Uses secateurs  
10:56 Uses Harrow rake  
10:57 Uses Brush rake  
10:58 Uses Harrow rake  
11:00 Whistle to stop work  
Section Commander does QA and uses spade to move processed spoil back in lane  
11:03 Section Commander finished QA

.....

11:20 Whistle to restart work  
11:22 Uses Harrow rake  
11:25 Uses Brush rake  
11:26 Uses spade to move processed spoil back in lane  
11:27 Uses Brush rake  
11:37 Uses Harrow rake  
11:45 New Heavy rake issued (first one has a tine bending)  
11:46 Uses spade to move processed spoil back in lane  
11:48 Uses Brush rake  
11:50 Whistle for rest break  
Section Commander does QA and uses spade to move processed spoil back in lane  
11:52 Section Commander finished QA

.....

12:10 Whistle to restart work  
12:13 Uses Harrow rake  
12:25 Uses spade to move processed spoil back in lane  
12:28 Uses Brush rake  
12:30 Third square metre completed  
12:33 Uses Harrow rake  
12:40 Whistle to stop work

Deminer and Section Commander pour 50L of water on Lane 1, 25L of water on Lane 2.

Paulino's calculations: Mines found: 1 Type 72. 172 square cms cleared in the day. No water used.

[1.72 square metres were cleared in 210 minutes, so giving an average advance rate of a metre every 122 minutes.]

**Trial 5, Lanes 1 and 2:** 18<sup>th</sup> November, ADP Team 3

**Monitor:** Paulino Gove

**Deminer:** Carlos Tembe

**Section Commander:** Fernando Laice

06:45 Whistle to start work

06:47 Deminer starts with Brush rake

06:49 Uses Harrow rake

06:54 Uses Brush rake

06:55 Uses spade to move processed spoil back in lane

06:56 Uses Brush rake

06:58 Uses Harrow rake

06:59 Uses Brush rake

07:00 Uses Harrow rake

07:04 Uses Brush rake

Uses spade to move processed spoil back in lane

07:05 Uses Brush rake

07:10 Uses Harrow rake

07:15 Stop for rest break

.....

07:35 Whistle to start work

07:37 Uses Harrow rake

07:38 Uses Brush rake

07:39 Uses spade to move processed spoil back in lane

07:40 Uses Brush rake

07:41 Uses Harrow rake

07:44 Uses Brush rake

07:45 Fourth square metre completed

07:49 Uses Harrow rake

07:58 Uses spade to move processed spoil back in lane

08:00 Uses Brush rake

08:02 Uses Harrow rake

08:05 Whistle for rest break

.....

08:25 Whistle to start work

08:27 Deminer starts with Brush rake

08:30 **MINE** located, GYATA, by Brush rake, 450 x 2cm, no damage [AVS: confirmed]

08:32 Continues after removal of mine  
08:34 Uses Harrow rake  
08:41 Uses spade to move processed spoil back in lane  
08:44 Uses Brush rake  
08:45 Uses Harrow rake  
08:53 Whistle for rest break  
.....  
09:15 Whistle to start work  
09:17 Uses spade to move processed spoil back in lane  
09:20 Uses Brush rake  
09:25 Uses Harrow rake for aligning the trench  
09:26 Uses spade to move processed spoil back in lane  
09:28 Uses Brush rake  
09:30 Uses Harrow rake  
09:38 Uses Brush rake  
09:41 Uses Harrow rake  
09:45 Whistle for rest break  
.....  
10:35 Whistle to start work  
10:37 Deminer restarts with Brush rake  
10:39 Uses spade to move processed spoil back in lane  
10:44 QA by section commander [checking side depth]  
10:45 Uses Harrow rake  
10:46 Fifth square metre completed  
QA tidies up trench  
10:54 Lane 1 QA completed  
[Paulino's calculations: Lane 1, 140 square cm completed: 1 GYATA located: 25 litres of water used.]  
10:55 Starts Lane 2  
Pours 50 litres of water over start area  
10:56 Mr Eric pushes soil in Lane 1 behind [tidying lane]  
11:05 Whistle for rest break  
.....  
11:25 Whistle to start work  
11:27 Deminer starts base-trench preparation outside the lane using a mattock and a spade  
Starts 25cm away from the start line  
11:46 Deminer starts working in front of the base-trench with Brush rake  
11:48 Uses Harrow rake  
11:55 Whistle for rest break  
.....

- 12:15 Whistle to start work
- 12:17 Deminer starts work with Harrow rake
- 12:30 Uses Brush rake
- 12:34 Uses secateurs to cut roots
- 12:36 Uses Harrow rake
- 12:41 Uses Brush rake
- 12:43 38 litres of water poured on working area
- 12:45 Whistle for end of trial

Paulino's calculations in Lane 2: 30 square cms cleared, no mines found, 63 litres of water applied.

[AVS checked the finish point in presence of Eric Stoa and measured it at 12cm into Lane 4 (to the bottom of the sloping edge in front of the Base trench).

### **Trial 5, Lanes 3 and 4:** 17<sup>th</sup> November, ADP Team 3

**Monitor:** Mate Gaal

**Deminer:** Januario Justino Mindo

**Section Commander:** Fernando Laice

The total area cleared was  $1.63 + 4.2 = 5.83$  square metres in a nominal 663 minutes, meaning an advance rate of a metre every 114 minutes. In fact, the lane width (to bottom of side trenches was a measured 12cm wider at full clearance depth. This means that the deminer cleared an area  $583 \times 112\text{cms}$ , or 6.5 square metres. The clearance rate was then approximately a metre every 102 minutes.

The deminer(s) found all surrogate mines in the cleared area, a total of 3. One surrogate was damaged in a way that was deemed very likely to have caused an initiation.

Deminer started work as soon as the equipment arrived, so starting for the last 30 minute session on the day.

[75 litres of water was poured over Lane 3 just before the trial started]

- 12:10 Whistle to start work
- 12:12 Deminer starts preparing the start trench using a mattock and shovel (outside the start of lane 3.
- 12:22 Start trench finished  
Uses Brush rake in lane
- 12:23 Changes to Harrow rake
- 12:27 Changes to Brush rake
- 12:29 Changes to Harrow rake
- 12:30 Changes to Brush rake
- 12:35 Changes to Harrow rake
- 12:37 Changes to Brush rake
- 12:39 Changes to Harrow rake
- 12:40 Whistle to stop work

**Trial 5, Lanes 3 and 4:** 18<sup>th</sup> November, ADP Team 3

**Monitor:** Mate Gaal, Manuel R. Django

**Deminer:** Januario Justino Mindo

**Section Commander:** Fernando Laice

06:46 Whistle to start work  
06:48 Uses Brush rake  
06:49 Uses Harrow rake  
06:51 Uses Brush rake  
06:52 Uses Harrow rake  
06:53 Uses Brush rake  
06:54 Uses Harrow rake  
06:55 Uses Brush rake  
06:58 Mattock used to move processed spoil back in lane  
06:59 Uses Harrow rake  
Uses Brush rake  
07:00 Uses Harrow rake  
07:01 Uses Brush rake  
07:03 Uses Harrow rake  
07:04 Damaged the Harrow rake handle [stick was damaged at the start]  
07:05 Uses Brush rake  
07:07 Uses Harrow rake  
07:08 Uses Brush rake  
07:10 Uses Harrow rake  
07:12 Uses Brush rake  
07:13 Uses Harrow rake  
07:14 The Harrow rake was changed  
07:16 Whistle for rest break  
.....  
07:36 Whistle to start work  
07:37 Uses Harrow rake  
07:40 Uses Brush rake  
07:41 Uses Harrow rake  
07:42 Uses Brush rake  
07:44 Uses Harrow rake  
07:46 Uses Brush rake  
07:47 Uses Harrow rake  
07:50 Uses Brush rake  
07:51 Uses Harrow rake (water used)  
07:53 Uses Brush rake  
07:55 Uses Harrow rake

07:57 Uses Brush rake  
07:58 Uses Harrow rake  
08:00 Uses Brush rake  
08:01 Mattock used to move processed spoil back in lane  
08:02 Uses Harrow rake  
08:04 Uses Brush rake  
08:05 QA by the Section Commander  
08:06 Whistle for rest break  
Water used  
.....  
08:26 Whistle to start work  
08:29 Uses Harrow rake  
08:31 Uses Brush rake  
08:33 Uses Harrow rake  
08:35 Uses Brush rake  
08:37 Uses Harrow rake  
08:41 Uses Brush rake  
08:43 Uses Harrow rake  
08:46 Uses Brush rake  
08:49 Uses Harrow rake  
08:52 Uses Brush rake  
08:53 Uses Harrow rake  
08:55 Uses Brush rake  
08:56 Whistle for rest break  
.....  
09:16 Whistle to start work  
09:18 Uses Harrow rake  
09:20 Uses Brush rake  
09:21 Uses Harrow rake  
09:23 Uses Brush rake  
09:24 Uses Harrow rake  
09:26 Uses Brush rake  
09:27 **MINE** located, GYATA, (80,100), damaged on top [AVS: top corner of the mine had been broken away. A tine point had penetrated the mine top by 2mm and when the rake was pulled, a piece of wood had broken off. This is thought very likely to have initiated a real GYATA mine.]  
09:29 Mine removed, uses Brush rake, water used  
09:31 Uses Harrow rake, water used  
09:34 Uses Brush rake  
09:35 Uses Harrow rake  
09:38 Uses Brush rake

09:39 Uses Harrow rake  
09:41 Uses Brush rake  
09:42 Uses Harrow rake  
09:43 Uses Brush rake  
09:44 Uses Harrow rake  
09:45 Uses Brush rake  
09:46 Whistle for rest break, water used  
.....  
10:36 Whistle to start work  
10:39 Deminer starts with Brush rake  
10:40 Uses Harrow rake  
10:41 Uses Brush rake  
10:42 Uses Harrow rake  
10:44 Uses Brush rake  
First square metre cleared  
10:45 Uses Harrow rake  
10:46 Uses Brush rake  
10:47 QA by Section commander, depth control  
10:48 Uses Harrow rake  
10:49 Uses Brush rake  
10:50 Uses Harrow rake  
Uses Brush rake  
Uses Harrow rake  
10:51 Uses Brush rake  
10:52 Uses Harrow rake  
Uses Brush rake  
10:53 Uses Harrow rake  
10:54 Uses Brush rake  
10:55 Uses Harrow rake  
10:57 Uses Brush rake  
11:00 QA by Section Commander, water used  
11:01 Uses Harrow rake  
11:02 Uses Brush rake  
11:04 Uses Harrow rake  
11:06 Uses Brush rake, water used  
Whistle for rest break  
.....  
11:26 Whistle to start work  
11:28 Deminer starts work with Harrow rake  
11:29 Uses Brush rake

Uses Harrow rake  
11:30 Uses Brush rake  
11:31 Uses Harrow rake  
11:32 Uses Brush rake  
11:34 Uses Harrow rake  
11:35 Uses Brush rake  
Uses Harrow rake  
11:37 Uses Brush rake  
11:38 Uses Harrow rake  
Uses Brush rake  
11:39 QA by Section Commander  
Uses Harrow rake, water used  
11:41 Uses Brush rake  
11:45 Uses Harrow rake  
11:50 Uses Brush rake  
11:52 Uses Harrow rake  
11:54 Uses Brush rake  
11:55 Uses Harrow rake  
11:56 Whistle for rest break  
.....  
12:16 Whistle to start work  
12:18 Deminer starts work with Harrow rake  
12:20 Uses Brush rake  
12:21 Uses Harrow rake  
12:22 Uses Brush rake  
12:24 Uses Harrow rake  
12:25 Uses Brush rake  
12:27 Uses Harrow rake  
12:28 Uses Brush rake  
12:29 QA by Section Commander  
12:30 Uses Harrow rake  
12:32 Uses Brush rake  
12:33 Uses Harrow rake  
12:35 Uses Brush rake  
12:36 Uses Harrow rake  
12:37 Uses Brush rake  
Uses Harrow rake  
12:38 Uses Brush rake  
12:39 Uses Harrow rake (water used)  
12:40 Uses Brush rake

12:42 Uses Harrow rake  
12:44 Uses Brush rake  
Second square metre cleared  
12:45 Uses Harrow rake  
12:46 Uses Brush rake  
Whistle to stop work  
Django's calculations: two square metres cleared, 1 GYATA mine found. 4 25 litre cans of water used = 100 litres.

**Trial 5, Lanes 3 and 4:** 19<sup>th</sup> November, ADP Team 3

**Monitor:** Manuel R. Django

**Deminer:** Januario Justino Mindo

**Section Commander:** Fernando Laice

05:56 Whistle to start work  
05:57 Uses Brush rake  
05:58 Uses Harrow rake  
06:01 Uses Brush rake  
06:02 Uses Harrow rake  
06:04 Uses Brush rake  
06:05 Uses Harrow rake  
06:06 Uses Brush rake  
06:07 Uses Harrow rake  
06:08 Uses Brush rake  
Uses Harrow rake  
06:09 Uses Brush rake  
06:10 Uses Harrow rake  
06:11 Uses Brush rake  
06:13 Uses Harrow rake  
06:14 Uses Brush rake  
06:16 Uses Harrow rake  
06:17 Section commander does QA  
Uses Harrow rake  
06:19 Uses Brush rake  
06:20 Uses Harrow rake  
06:22 Uses Brush rake  
06:23 Uses Harrow rake  
06:24 Uses Brush rake  
Uses Harrow rake  
06:26 Whistle for rest break

.....

06:41 Whistle to start work  
06:43 Deminer starts with Harrow rake  
06:44 Uses Brush rake  
          Uses Harrow rake  
06:45 Uses Brush rake  
06:46 Uses Harrow rake  
06:47 Uses Brush rake  
06:48 Uses Harrow rake  
          Uses Brush rake  
06:49 Uses Harrow rake  
06:50 Uses Brush rake  
06:51 Uses Harrow rake  
          Uses Brush rake  
06:52 Section Commander does QA  
          Uses Harrow rake  
06:53 Uses Brush rake  
          Uses Harrow rake  
06:55 Uses Brush rake  
06:58 Uses Harrow rake  
06:59 Uses Brush rake  
07:00 Uses Harrow rake  
07:01 Uses Brush rake  
07:02 Uses Harrow rake  
07:05 Uses Brush rake  
07:07 Uses Harrow rake  
07:08 Uses Brush rake  
07:09 Uses Harrow rake  
07:10 Uses Brush rake  
07:11 Whistle for rest break  
          Section Commander does QA and moves processed spoil back with spade  
.....  
07:26 Whistle to start work  
07:28 Uses Harrow rake  
07:29 Uses Brush rake  
07:31 Uses Harrow rake  
07:33 Uses Brush rake  
          Uses Harrow rake  
07:34 Uses Brush rake  
07:35 Uses Harrow rake  
          Uses Brush rake

07:36 Uses Harrow rake  
07:37 Uses Brush rake  
07:38 Uses Harrow rake  
07:39 Uses Brush rake  
07:40 Uses Harrow rake  
07:41 Uses Brush rake  
07:42 Cutting roots with secateurs  
07:44 Uses Harrow rake  
07:45 Uses Brush rake  
07:47 Uses Harrow rake  
07:48 Uses Brush rake  
07:49 Uses Harrow rake  
07:50 Uses Brush rake  
Uses Harrow rake  
07:51 Uses Brush rake  
07:52 Uses Harrow rake  
Uses Brush rake  
07:53 Uses Harrow rake  
07:55 Uses Brush rake  
Third square metre achieved  
07:56 Whistle for rest break  
Section Commander uses mattock to level the soil  
.....  
08:11 Whistle to start work  
08:13 Uses Harrow rake  
08:16 Uses Brush rake  
08:18 Uses Harrow rake  
08:19 Uses Brush rake  
08:20 Uses Harrow rake  
08:21 Uses Brush rake  
08:22 Uses Harrow rake  
08:24 Uses Brush rake  
08:25 Uses Harrow rake  
08:26 Uses Brush rake  
Uses Harrow rake  
08:27 Uses Brush rake  
08:30 Uses Harrow rake  
08:32 Uses Brush rake  
08:33 Uses Harrow rake  
08:34 Uses Brush rake

08:35 Uses Harrow rake  
08:36 Uses Brush rake  
08:37 Section Commander uses spade to move processed spoil back in lane  
08:38 Uses Brush rake  
08:39 Section Commander does QA  
08:40 Uses Harrow rake  
Uses Brush rake  
08:41 Uses Harrow rake  
Whistle for rest break  
.....  
08:56 Whistle to start work  
08:58 Uses Brush rake  
08:59 Uses Harrow rake  
09:00 Uses Brush rake  
09:01 Water used  
Uses Brush rake  
09:03 Uses Harrow rake  
09:08 Uses Brush rake  
09:10 Uses Harrow rake  
09:12 Uses Brush rake  
09:13 Uses mattock to move processed spoil back in lane  
09:15 Section Commander does QA  
09:17 Uses Brush rake  
09:20 Uses Harrow rake  
09:22 Uses Brush rake  
09:23 Uses Harrow rake  
09:24 Uses Brush rake  
09:26 Whistle for rest break  
.....  
09:41 Whistle to start work  
09:43 Uses Harrow rake  
09:44 Uses Brush rake  
09:45 Uses Harrow rake  
09:46 Uses Brush rake  
09:48 Uses Harrow rake  
09:50 Uses Brush rake  
09:51 Uses Harrow rake  
09:52 Uses Brush rake, Uses Harrow rake  
09:53 Uses Brush rake, water used  
09:54 Waits for water collected by Section Commander

09:55 Water used, Waiting for water to soak in  
09:57 Uses Harrow rake  
09:58 Waiting for water to soak in  
10:00 Uses Brush rake  
10:02 Uses Harrow rake  
10:04 Uses Brush rake  
10:07 Uses Harrow rake  
10:08 Section Commander uses spade to move processed spoil back in lane  
10:10 Uses Brush rake  
10:11 Whistle to stop for rest break  
Section Commander performs QA  
.....  
10:25 Whistle to start work  
10:29 Deminer starts with Harrow rake  
10:32 Uses Brush rake  
10:33 Uses Harrow rake  
10:35 **MINE** located, GYATA (420, 80) pulled with Harrow rake, no damage [AVS: confirmed]  
10:37 Uses Brush rake  
10:38 Uses Harrow rake  
10:39 Uses Brush rake  
10:40 Uses Harrow rake, water used  
10:43 Uses spade to move processed spoil back in lane  
10:46 Uses Harrow rake  
10:47 Uses Brush rake  
10:48 Uses Harrow rake  
10:49 Uses Brush rake  
10:50 Uses Harrow rake  
Fourth square metre cleared  
10:51 Uses Brush rake  
10:52 Section Commander does QA  
10:54 Uses Harrow rake  
10:55 Uses Brush rake  
10:56 Whistle to stop work  
Django's calculations: 1.9 square metres cleared: 1 GYATA discovered, undamaged. 20 litres of water used. Yesterday, 2 x 25 litres of water were poured on the lane.

**Trial 5, Lanes 3 and 4 [nominal]:** 19<sup>th</sup> November, ADP Team 3

**Monitor:** Paulino

**Deminer:** Helder Martins Afido

**Section Commander:** Fernando Laice

[To complete the time requirement within the trials – which must end on this day – another deminer is used to work in the unfinished parts of Lane 1 and 2 and his cleared area added to that recorded for Lanes 3 and 4. The deminer in 3 and 4 cannot complete 3 hours of the trial, and this compromise was agreed between monitors and the REDS trainer.]

05:55 Whistle to start work  
05:56 Start with Harrow rake  
06:00 Uses Brush rake  
06:06 Uses Harrow rake  
06:09 Uses Brush rake  
06:10 Uses Harrow rake  
06:13 Uses Brush rake  
06:15 Uses Harrow rake  
06:17 Uses Brush rake  
06:20 Uses Harrow rake  
06:21 Uses Brush rake  
06:23 Uses Harrow rake  
06:25 Whistle for rest break  
.....  
06:40 Whistle to start work  
06:41 Deminer starts with Harrow rake  
06:43 Uses Brush rake  
06:45 Uses Harrow rake  
06:46 Uses Brush rake  
06:48 Uses Harrow rake  
06:50 Uses Brush rake  
06:51 Uses Harrow rake  
06:54 Uses Brush rake  
06:56 Uses Harrow rake  
07:00 Uses Brush rake  
07:02 Uses Harrow rake  
07:04 Uses Brush rake  
07:05 Uses Harrow rake  
07:08 Uses Brush rake  
07:10 Whistle for rest break  
.....  
07:25 Whistle to start work  
07:26 Deminer starts with Harrow rake  
07:30 Uses Brush rake  
07:32 Uses Harrow rake  
07:37 Uses Brush rake  
07:38 Uses Harrow rake

07:42 Uses Brush rake  
07:46 Uses Harrow rake  
07:49 Uses Brush rake  
07:50 First square metre is completed  
07:52 Uses Brush rake  
07:53 Uses Harrow rake  
07:54 Uses Brush rake  
07:55 Whistle for rest break  
.....  
08:10 Whistle to start work  
08:13 Deminer starts with Harrow rake  
08:23 Uses Brush rake  
08:25 Uses Harrow rake  
08:28 Uses spade to move processed spoil back in lane  
08:30 Uses Brush rake  
08:32 Uses Harrow rake  
08:34 Uses Brush rake  
08:36 Uses Harrow rake  
08:40 Uses Brush rake  
08:40 Whistle for rest break  
08:41 Section Commander does QA, moves soil behind, checks depth  
08:42 QA finished  
.....  
08:55 Whistle to start work  
08:57 Deminer starts with Harrow rake  
09:00 Uses Brush rake  
09:03 Uses Harrow rake  
09:08 Uses Brush rake  
09:09 Five litres of water applied  
Uses Brush rake  
09:11 Uses Harrow rake  
09:15 Uses Brush rake  
09:16 Uses spade to move processed spoil back in lane  
09:17 Uses Brush rake  
09:19 Uses Harrow rake  
09:22 Uses Brush rake  
09:29 Uses Harrow rake  
09:25 Whistle for rest break  
.....  
09:40 Whistle to start work

- 09:41 Deminer restarts with Harrow rake
- 09:43 Section Commander uses spade to move processed spoil from lane  
Uses Harrow rake
- 09:44 Uses Brush rake
- 09:47 Uses Harrow rake
- 09:50 Uses Brush rake
- 09:53 The deminer stopped to watch the demonstration to guests at the site
- 09:54 Deminer continues with Brush rake
- 09:57 Uses Harrow rake
- 09:59 Uses Brush rake
- 10:01 Uses Harrow rake
- 10:03 **MINE** located, Type 72 (175, 65), uncovered by brush rake: undamaged [AVS: confirmed]
  
- 10:06 Deminer continues with Brush rake after mine removed
- 10:09 Uses Harrow rake
- 10:10 Whistle for rest break
- .....
- 10:25 Whistle to start work
- 10:27 Deminer starts with Brush rake
- 10:30 Uses Harrow rake
- 10:35 Uses Brush rake
- 10:36 Uses spade to move processed spoil back in lane  
Uses Harrow rake
- 10:37 Uses Brush rake
- 10:39 Uses Harrow rake
- 10:41 Uses Brush rake
- 10:43 Uses Harrow rake
- 10:46 Uses Brush rake
- 10:50 Uses Harrow rake
- 10:51 Five litres of water poured on working area  
Uses Harrow rake
- 10:55 Uses Brush rake  
Whistle to stop work

Paulino's calculations: 190 square cms cleared in lane [175 square cms – AVS]

1 Type 72 cleared, 10 litres of water used

## **Trial 6: ADP spade excavation:**

The trial involved area-excavation (no metal-detection) using the ADP tools and a spade. In the 10 metre test area (comprising two five metre long lanes), 8 targets had been concealed, four Type-72 surrogates and 4 GYATA surrogates. "Natural" fragment contamination was removed from the surface, but not from sub-surface sources. No fragments were deliberately added.

### **Trial 6: Lanes 1 and 2:** 9<sup>th</sup> November, ADP Team 1

**Monitor:** Mate Gaal

**Deminer:** Helder Martins Afido

**Section Commander:** Dionisio Chaka

All eight target mines were discovered by the deminer. Four had no damage. Two showed signs of having been struck on the side. Two had been struck on the top edge by the spade. Both top damaged mines were Type 72 surrogates. The pressure plate of the Type 72 does not extend to the edge of the mine, and is not easy to press on the sides, so it is considered unlikely that either mine would have functioned.

The deminer worked a total (nominal) 494 minutes (-29) in the 10 metre area (including the square metre start "base-trench"). -25 minutes for trench 1. -28 minutes for trench 2, so 53 minutes were spent preparing start areas rather than clearance, Actual work in the lanes was only for 441 minutes, giving an average advance of one metre in every 44 minutes.

07:00 Start

[Deminer has already poured 12.5 litres of water over the first 0.5m of the lane and on the metre in front of the lane (where he will dig the start trench 1 x 1m in size and 15-20cm deep)]

07:25 Start to advance into the lane.

[Kneeling, hitting the soil sideways with his shovel: prodding, removing bits of soil with his prod (photos); putting water on the area in front of the base-trench.]

07:30 Deminers stops for rest break

Section Commander adds water to the area in front of the base-trench.

07:31 Section Commander stops

25 litres of water has been applied to the start of lanes 1 and 3, half in each lane.

.....

07:50 Whistle to restart work

07:54 Deminer restarts work in lane

[Deminer uses a T-profile prod to loosen the hard soil below 10cm depth. He then prods with the standard prodder and removes soil with trowel when needed. After prodding he slices the earth away using the spade from one side.]

08:20 Whistle to stop work

Deminer stops and pours black bucket of water over area in front of base-trench before leaving.

.....

08:40 Whistle to start work

08:43 Deminer starts work in lane

08:45 Pours blue bucket of water over area in front of base trench.

08:46 **MINE** discovered, Type 72 (70, 80), No damage [AVS: confirmed]

08:47 Deminer continues after mine is removed

09:10 Whistle to stop work

Black bucket of water applied to area in front of base-trench

.....

09:30 Whistle to start work

09:32 Section Commander shovels soil from the base-trench

09:32 Section Commander stops

09:33 Deminer starts work

09:36 One square metre completed

09:40 Blue bucket of water applied to area in front of base-trench

09:45 Black bucket of water applied to area in front of base-trench

09:56 Half a blue bucket of water applied to area in front of base-trench

09:58 Two and a half blue buckets of water applied to area in front of base-trench

10:00 Whistle to stop work

.....

10:50 Whistle to start work

10:54 Deminer starts work in lane

Blue bucket of water applied to area in front of base-trench

11:07 Blue bucket of water applied to area in front of base-trench

11:09 Second square metre completed

11:19 Blue bucket of water applied to area in front of base-trench

11:20 Blue bucket of water applied to area in front of base-trench

Whistle to stop work

.....

11:40 Whistle to start work

11:45 Deminer starts work in lane

11:47 Blue bucket of water applied to area in front of base-trench

12:03 **MINE** discovered, Type 72 at 12cm (290, 10), damaged on top edge by spade. [AVS: damage did not extend to the edge of the pressure plate and was unlikely to have initiated the mine.]

12:06 Work continues after mine removal

12:07 Blue bucket of water applied to area in front of base-trench

12:10 Whistle to stop work

Blue bucket of water applied to area in front of base-trench

.....

12:30 Whistle to start work

12:33 Deminer starts work in lane

12:35 Blue bucket of water applied to area in front of base-trench

12:36 Three square metres completed

12:51 Blue bucket of water applied to area in front of base-trench

13:00 Whistle to stop work

Blue bucket of water applied to area in front of base-trench

**Trial 6: Lanes 1 and 2:** 10<sup>th</sup> November, ADP Team 1

**Monitor:** Mate Gaal

**Deminer:** Helder Martins Afido

**Section Commander:** Dionisio Chaka

- 06:42 Whistle to start work
- 06:43 Deminer starts work in lane
- 06:44 **MINE** discovered, Type 72 at one centimetre, (360, 30), no damage [AVS: confirmed]  
[This deminer only uses the spade, no prodder]  
Less than a minute to remove mine.
- 07:02 Trowel used for the first time today, also T prodder to loosen hard soil. Deminer continues advancing by slicing away soil with spade.
- 07:09 Fourth square metre completed.
- 07:10 Whistle to stop work
- .....
- 07:33 Whistle to start work  
Deminer fills water buckets and applies three buckets of water
- 07:38 Deminer starts excavating in lane
- 07:47 Applies one bucket of water in front of base-trench
- 07:49 T-prodder to prod then twist to loosen soil
- 07:51 Deminer returns to using shovel
- 07:53 Thin prodder used on Section Commander's instructions
- 07:54 Deminer returns to using shovel
- 07:55 **MINE** discovered, GYATA at one centimetre, (450, 0), mine side scrape [AVS: confirmed]
- 07:56 Deminer continues after mine removal
- 08:03 Whistle to stop work. Deminer applies bucket of water in front of base-trench  
Section Commander waters start of next lane
- .....
- 08:23 Whistle to start work
- 08:26 Deminer starts work in lane
- 08:34 Used T-prod to break hard soil
- 08:39 Fifth square metre (Lane 1) completed  
Section commander prods to check end of lane
- 08:41 Section Commander finishes QA  
Deminer starts digging square metre outside Lane 2 as base-trench
- 08:45 Deminer applies bucket of water in front of base-trench
- 08:54 Whistle to stop work
- .....
- 09:13 Whistle to start work
- 09:25 Deminer applies bucket of water in front of base-trench
- 09:28 Deminer starts to advance into lane. Uses thin prod first, then T prod to loosen hard soil.

- 09:31 Resumes with spade
- 09:33 Deminer applies bucket of water in front of base-trench
- 09:41 Deminer applies two buckets of water in front of base-trench
- 09:43 Whistle to stop work  
Deminer applies bucket of water in front of base-trench
- .....
- 10:30 Whistle to start work
- 10:31 Deminer starts work in lane
- 10:38 **MINE** discovered, GYATA at 12cm, (60, 80), damaged on top corner: [AVS: confirmed, damage 4mm deep on the top edge is likely to have caused an initiation of a real GYATA]
- 10:41 Deminer continues after mine is removed
- 10:42 Deminer applies two blue buckets of water in front of base-trench
- 10:49 Deminer applies blue bucket of water in front of base-trench
- 10:55 Deminer applies blue bucket of water in front of base-trench
- 11:00 Whistle to stop work
- .....
- 11:20 Whistle to start work
- 11:23 Deminer starts work in lane
- 11:28 Deminer applies blue bucket of water in front of base-trench
- 11:31 First square metre of lane 2 cleared
- 11:32 Deminer applies blue bucket of water in front of base-trench
- 11:37 **MINE** discovered, GYATA at 1cm, (130, 30), no damage: [AVS: confirmed]
- 11:38 Deminer continues after mine is removed
- 11:50 Whistle to stop work  
Deminer applies two blue buckets of water in front of base-trench
- .....
- 12:13 Whistle to start work
- 12:16 Deminer starts work in lane
- 12:23 **MINE** discovered, GYATA at 12cm, (195, 70), no visible damage: [AVS: confirmed]
- 12:26 Deminer starts work after mine removal
- 12:27 Second square metre of Lane 2 completed
- 12:30 Deminer applies bucket of water in front of base-trench  
[Deminer is tiring, cutting noticeably slower]
- 12:43 Whistle to stop work  
[Stopped at 2.3 metres]

**Trial 6: Lanes 1 and 2:** 11<sup>th</sup> November, ADP Team 1

**Monitor:** Mate Gaal

**Deminer:** Helder Martins Afido

**Section Commander:** Dionisio Chaka

06:56 Whistle to start work, Deminer starts work in lane  
07:02 Deminer applies black bucket of water in front of base-trench  
07:16 Third square metre of lane 2 completed  
07:18 Deminer applies blue bucket of water in front of base-trench  
07:26 Deminer applies blue bucket of water in front of base-trench  
Whistle to stop work  
Deminer applies black bucket of water in front of base-trench  
[Work is at 340cm]  
.....  
07:45 Whistle to start work  
07:48 Deminer starts work in lane  
Deminer applies black bucket of water in front of base-trench  
07:58 Deminer applies black bucket of water in front of base-trench  
Deminer applies blue bucket of water in front of base-trench  
08:03 Fourth square metre of Lane 2 completed  
08:10 **MINE** discovered, Type 72 at 12cm, (430, 98), cut to upper corner [AVS: confirmed]  
08:13 Work continues after mine removal  
08:15 Whistle for rest break  
Deminer applies blue bucket of water in front of base-trench  
Deminer applies black bucket of water in front of base-trench  
08:16 Deminer applies blue bucket of water in front of base-trench  
Deminer applies black bucket of water in front of base-trench  
08:17 Deminer leaves for rest area  
.....  
08:37 Whistle to start work, Deminer starts work in lane  
08:49 Deminer finishes fifth square metre and Lane 2.  
08:50 Section Commander cleans the last 50cm, prods ahead of the end of lane  
08:51 QA finished.

## **Trial 6: Lanes 3 and 4:** 9<sup>th</sup> November: ADP Team 1

**Monitor:** Mate Gaal

**Deminer:** Carlos Tembe

**Section Commander:** Dionisio Chaka

All eight target mines were discovered by the deminer. Three had no damage. Five showed signs of having been struck on the side. One Type 72 showed signs of having been hit on the top by a prodder, not the spade. The damage was very light and not thought likely to have initiated a real device.

The deminer worked a total (nominal) 540 minutes (-21) in the 10 metre area (including the square metre start "base-trench"). -37 minutes for trench 1. -36 minutes for trench 2, so 73 minutes were spent preparing start areas rather than clearance, Actual work in the lanes was only for 467 minutes, giving an average advance of one metre in every 47 minutes.

07:00 Start

[Deminer has already poured 12.5 litres of water over the first 0.5m of the lane and on the metre in front of the lane (where he will dig the start trench 1 x 1m in size and 15-20cm deep)]

[Shovelling out a square metre trench to approx 20cm depth in front of Lane 1.]

07:30 Stop for rest break

.....

07:50 Whistle to start work

07:53 Deminer starts work in start trench

08:00 Deminer starts to advance into lane.

Blue bucket of water applied to area in front of base-trench

08:20 Whistle to stop work

Black bucket of water applied to area in front of base-trench

08:22 Deminer stops and leaves for rest area

.....

08:40 Whistle to start work

08:43 Deminer starts work in lane

08:44 **MINE** discovered, Type 72 at 12 cm (50, 30), prodded on top, damaged on side. [AVS: confirmed]

08:46 Deminer continues work after mine removal

09:01 Blue bucket of water applied to area in front of base-trench

Black bucket of water applied to area in front of base-trench

09:10 Whistle to stop work

Blue bucket of water applied to area in front of base-trench

Black bucket of water applied to area in front of base-trench

09:12 Deminer stops work and leaves for rest area

.....

09:30 Whistle to start work

09:33 Deminer starts work in lane

09:41 **MINE** discovered, GYATA at 12cm, (90, 98), two hits evident on side of mine [AVS: confirmed]

09:45 Deminer continues after mine removed

Black bucket of water applied to area in front of base-trench

09:50 half a blue bucket of water applied to area in front of base-trench  
half a black bucket of water applied to area in front of base-trench  
09:55 One square metre completed  
10:00 Whistle to stop work  
Black bucket of water applied to area in front of base-trench  
.....  
10:50 Whistle to start work  
10:54 Deminer starts work in lane  
Blue bucket of water applied to area in front of base-trench  
11:10 Blue bucket of water applied to area in front of base-trench  
11:19 Blue bucket of water applied to area in front of base-trench  
11:20 Whistle to stop work  
.....  
11:40 Whistle to start work  
11:44 Deminer starts work in lane  
11:48 Blue bucket of water applied to area in front of base-trench  
12:02 Two square metres completed  
12:05 Blue bucket of water applied to area in front of base-trench  
12:10 Whistle to stop work  
Blue bucket of water applied to area in front of base-trench  
.....  
12:30 Whistle to start work  
12:33 Deminer starts work in lane  
12:42 **MINE** discovered, GYATA at 1cm (250, 70), very slight damage on side [AVS: confirmed]  
12:43 Deminer continues after mine removal  
12:50 Blue bucket of water applied to area in front of base-trench  
13:00 Whistle to stop work  
Blue bucket of water applied to area in front of base-trench  
Worked a nominal 210 minutes (-16)

**Trial 6: Lanes 3 and 4:** 10<sup>th</sup> November, ADP Team 1

**Monitor:** Mate Gaal

**Deminer:** Carlos Tembe

**Section Commander:** Dionisio Chaka

06:42 Whistle to start work  
06:43 Deminer starts work in lane  
Deminer prods unsystematically, only to one depth, skipping some hard areas  
06:52 **MINE** discovered, GYATA at 1cm, (300,10), no damage [AVS: confirmed]  
06:53 Deminer continues after mine removal  
06:55 Third square metre of Lane 3 completed

- 07:10 Whistle to stop work  
.....
- 07:33 Whistle to start work  
Deminer fills a bucket of water and applies in front of base-trench
- 07:39 Deminer starts work in lane
- 07:47 Bucket of water applied to area in front of base-trench
- 07:51 Bucket of water applied to area in front of base-trench
- 07:55 Fourth square metre of Lane 3 completed
- 08:00 Deminer applies two buckets of water to area in front of base-trench
- 08:03 Whistle to stop work  
Deminer applies a bucket of water to area in front of base-trench  
.....
- 08:23 Whistle to start work
- 08:25 Deminer starts work in lane
- 08:51 Fifth square metre completed.  
Section Commander checks lane
- 08:52 Section Commander's check completed  
Start to excavate new start area in front of Lane 4
- 08:54 Whistle to stop for rest break  
Deminer applies 25 litre container of water on area in front of lane 4  
.....
- 09:13 Whistle to start work
- 09:16 Deminer starts work in front of lane
- 09:17 Two buckets of water applied to area
- 09:35 Deminer applies bucket of water to area
- 09:40 Deminer applies three buckets of water to area
- 09:43 Whistle for rest break  
.....
- 10:30 Whistle to start work
- 10:31 Deminer starts work in lane
- 10:37 Start area (one square metre in front of lane) is completed  
Deminer starts to advance base-trench into lane
- 10:48 Deminer applies blue bucket of water in front of base-trench
- 10:50 Deminer applies blue bucket of water in front of base-trench
- 10:53 **MINE** discovered, Type 72 at 12cm, (50, 40), no damage [AVS: confirmed]
- 10:54 Deminer continues after mine removal  
Deminer applies blue bucket of water in front of base-trench
- 11:00 Whistle for rest break  
Deminer applies three blue buckets of water in front of base-trench
- 11:03 Deminer leaves for rest break

.....

11:20 Whistle to start work  
11:23 Deminer starts work in lane  
11:35 Deminer applies two blue buckets of water in front of base-trench  
11:44 First square metre of lane 4 completed  
11:50 **MINE** discovered, Type 72 at 1cm, (110, 98) [no damage recorded] [AVS: confirmed no damage]  
Removal of mine took less than a minute  
Whistle to stop for rest break  
11:51 Deminer applies two blue buckets of water in front of base-trench

.....

12:13 Whistle to start work  
12:16 Deminer starts work in lane  
12:43 Whistle to stop work  
[Deminer is at 1.7m in Lane 4.]

Worked a nominal 210 minutes (-3).

### **Trial 6: Lanes 3 and 4: 11<sup>th</sup> November**

**Monitor:** Mate Gaal

**Deminer:** Carlos Tembe

**Section Commander:** Dionisio Chaka

06:56 Whistle to start work  
Deminer starts work in lane  
06:58 Deminer applies blue bucket of water in front of base-trench  
07:05 Investigation of a large object at 200, 80  
[This was only an area of very hard soil]  
07:08 Deminer applies blue bucket of water in front of base-trench  
07:15 Second square metre of Lane 4 completed  
07:16 **MINE** discovered, GYATA at 12cm, (210, 30), damage to side of mine [AVS: confirmed]  
07:18 Deminer continues after mine is removed  
07:19 Deminer applies blue bucket of water in front of base-trench  
07:26 Deminer applies blue bucket of water in front of base-trench  
Whistle to stop for rest break  
The lane is at 215cm

.....

07:45 Whistle to start work  
07:48 Deminer starts work in lane  
Deminer applies blue bucket of water in front of base-trench  
07:57 Deminer applies two blue buckets of water in front of base-trench  
07:59 Deminer applies two blue buckets of water in front of base-trench

- 08:14 Third square metre of Lane 4 is completed.
- 08:15 Whistle for rest break  
Deminer applies two blue buckets of water in front of base-trench
- 08:16 Deminer applies two blue buckets of water in front of base-trench
- 08:17 Deminer leaves for rest area
- .....
- 08:34 Whistle to start work
- 08:37 Deminer starts work in lane
- 08:45 Deminer applies two blue buckets of water in front of base-trench
- 09:04 Whistle for rest break  
Deminer applies three blue buckets of water in front of base-trench
- 09:06 Deminer leaves for rest area
- .....
- 09:25 Whistle to start work
- 09:28 Deminer starts work in lane
- 09:31 Fourth square metre completed in Lane 4
- 09:33 **MINE** discovered, Type 72 at 1cm, (410, 70), damaged on side, lower [AVS: confirmed] Less than a minute lost for mine removal  
Deminer works without prodding, chopping slices away from the face of the excavation with the spade, working from the side. Some slices are thin, some 7- 8 cm thick.
- 09:40 Deminer applies two blue buckets of water in front of base-trench
- 09:45 Deminer applies blue bucket of water in front of base-trench
- 09:47 deminer prods a little on the right side, continues with spade
- 09:53 Deminer finishes Lane 4  
Section Commander cleans last 50cm, prods ahead of the end of the lane, removes a little more soil with the spade, a few cm.
- 09:55 QA finished.

Worked a nominal 120 minutes (-2?).

## Trial 7: NPA short-tool excavation

The trial involved area-excavation (no metal-detection) using the NPA tools and system.

In the 10 metre test area (comprising two five metre long lanes), 8 targets had been concealed, four Type-72 surrogates and 4 GYATA surrogates. "Natural" fragment contamination was removed from the surface, but not from sub-surface sources. No fragments were deliberately added. No metal detector was used.

This trial was carried out by NPA deminers and under the supervision of an NPA QA man acting as their Section Commander. The deminers wore NPA PPE and used the NPA marking system.

Tools used were a short excavation tool, a candytwist re-bar prodder and secateurs. Other tools were available in the standard NPA toolkit.

### Trial 7: Lanes 1 and 2: 9<sup>th</sup> November, NPA Team

**Monitor:** Manuel R. Django

**Deminer:** Quisito Armando

**Section Commander:** Nuno Satar

Work started 30cm outside the lane marking at a depth less than 13cm (approx 10cm). The deminer progressed at an erratic depth that was measured at between 7 and 12cm.

1 mine was located, a GYATA at 1cm, undamaged. The total area cleared was 3.32 square metres. (front of trench was at 3.5 but trench sloped back to 3.32). A total of 632 minutes work was carried out (- 108 minutes putting on PPE and preparing before reaching the lanes). The average speed of advance was 190 minutes per square metre, or 3 hours ten minutes for each square metre.

07:01 Start work

Water used at 0cm at base of lane [The deminer started at the base-line: he did not make an excavation trench at the start of the lane.]

07:17 Water used

07:31 Stop for rest break

.....

07:51 Whistle to start work

07:56 Deminer starts work in lane

08:14 Water used

08:21 Stop for rest break

.....

08:41 Whistle to start work

08:42 **MINE** discovered, GYATA at 1cm, (70,10) [AVS: confirmed undamaged]

Water used

08:51 Water used (1 bucket used in total so far)

08:58 Water used

09:11 Stop for rest break

Apply water

.....

09:31 Restart work

09:45 First meter cleared

Water used

10:01 Stop for rest break  
Apply water (2<sup>nd</sup> bucket emptied)

.....

10:51 Restart work

11:07 Water used

11:11 Water used

11:20 Water used (3<sup>rd</sup> bucket emptied)

11:21 Whistle for rest break

.....

11:41 Work restarts

12:11 Stop for rest break

Water used

.....

11:31 Restart work

Water used (4<sup>th</sup> bucket emptied)

13:01 Whistle for end of work

1.6 Square metres cleared: 4 buckets of water used; 1 GYATA mine found

[The deminers only started to put on PPE after the whistle to start work and were usually between 3 and 5 minutes late reaching the lane. The deminer in Lane 1 did not clear to a regular depth: measured depth was 10cm maximum.]

[210 minutes worked, - approx 35 minutes inactive time]

### **Trial 7: Lanes 1 and 2:** 10<sup>th</sup> November, NPA Team

**Monitor:** Manuel R. Django

**Deminer:** Quisito Armando

**Section Commander:** Nuno Satar

06:45 Whistle to start work

07:11 Stop for rest break

Water used

.....

07:31 Restart work

08:01 Stop for rest break

.....

08:21 Restart work

08:52 Whistle for rest break

.....

09:11 Restart work

09:41 Stop for rest break

Water used (1 bucket used so far)

.....

10:31 Whistle to start work  
10:50 Two metre mark passed  
11:01 Stop for rest break

.....

11:21 Whistle to start work  
11:51 Stop for rest break

.....

12:11 Restart work  
12:41 Whistle to stop work  
Base trench at 225cm  
2 buckets of water used  
75cm done in the day.

[210 minutes worked, - approx 38 inactive time]

**Trial 7: Lanes 1 and 2:** 11<sup>th</sup> November, NPA Team

**Monitor:** Manuel R. Django

**Deminer:** Quisito Armando

**Section Commander:** Nuno Satar

06:57 Whistle to start work  
07:18 Water used  
07:27 Stop for first rest break

.....

[Depth measured during break – varied from 7cm to 12cm depth.]

07:46 Restart work  
08:00 Water used  
08:16 Stop for rest break

.....

08:36 Restart work  
08:56 Water used (First bucket emptied)  
09:00 Water used  
09:06 Whistle for rest break

.....

09:26 Restart work  
09:34 Water used  
09:54 Water used (Second bucket emptied)  
09:56 Whistle for rest break  
Water used

.....

[Delay for rain]

11:19 Restart work  
11:41 Water used  
11:51 Stop for rest break  
.....  
12:06 Restart work  
12:13 Third square metre marker passed  
12:36 Stop for rest break  
.....  
12:51 Restart work  
13:10 Water used (Third bucket emptied)  
13:21 Whistle to stop work  
Deminer is at 350cm

1.25 square metres cleared; 3 large buckets of water used

[212 minutes worked, - approx. 35 minutes inactive time]

[AVS: correction, deminer's total advance was measured at 3.32 metres.]

Section Commander paid scant attention to the deminers (sat in shade and on cell phone) and did not correct erratic depth maintenance. No QA was apparent. Monitors did not comment.

### **Trial 7: Lanes 3 and 4:** 9<sup>th</sup> November, NPA Team

**Monitor:** Manuel R. Django

**Deminer:** Joao Horacio

**Section Commander:** Nuno Satar

Work started 35cm outside the lane at a depth of 11cm.

Four mines were located, two Type 72s and two GYATAs. One mine was damaged on the side. The total area cleared was five square metres over three days.

A total of 631 minutes of work were recorded (- approx 105 inactive minutes) and five metres were cleared. The advance rate was at an average of 126 minutes per metre, or two hours and six minutes per metre.

07:01 Start work  
Water used (25cm on base lane)  
07:22 Water used  
07:31 Stop for rest break  
.....  
07:51 Whistle to start work  
07:56 Deminer in lane  
08:21 Stop for rest break  
.....  
08:41 Whistle to start work

08:52 Water used  
08:59 Water used  
09:05 **MINE** discovered, Type 72 at 12cm, (50, 50), No damage recorded. [AVS: confirmed]  
09:11 Stop for rest break  
.....  
09:31 Restart work  
Water used (1 bucket of water so far)  
09:56 Water used  
10:01 Stop for rest break  
Second bucket of water poured on working area  
.....  
10:51 Restart work  
11:19 Water used  
11:21 Stop for rest break  
.....  
11:41 Restart work  
11:57 Water used  
12:03 Water used  
12:11 Stop for rest break  
Water used  
.....  
12:31 Restart work  
12:43 Water used  
13:01 Stop work

Less than a square metre cleared; three buckets of water used; 1 Type 72 mine found.  
[This deminer maintained a measured depth of between 12 and 15 cm.]  
[A total of 210 minutes work was recorded, - approximately 35 minutes inactive time.]

**Trial 7: Lanes 3 and 4:** 10<sup>th</sup> November, NPA team

**Monitor:** Manuel R. Django

**Deminer:** Joao Horacio

**Section Commander:** Nuno Satar

06:43 Start work (at 110cm)  
Water applied  
06:55 Water applied  
07:03 Water applied  
07:09 Water applied  
07:11 Whistle for rest break  
Water applied (First bucket emptied)  
.....

07:31 Restart work  
07:33 Water used  
07:46 Water used  
08:01 Whistle for rest break  
Water used  
.....  
08:21 Restart work  
08:25 Water used  
08:47 Water used  
08:52 Whistle for rest break  
Water used (Second bucket emptied)  
.....  
09:11 Restart work  
09:22 Water used  
09:35 Water used  
09:41 Whistle for rest break  
Water used (third bucket emptied)  
.....  
10:31 Restart work  
10:54 Water used (210cm)  
11:01 Whistle for rest break  
Water used  
.....  
11:21 Restart work  
11:40 **MINE** discovered, GYATA at 1cm (255, 40), marked by prodder on side [AVS: confirmed]  
11:50 Water used  
11:51 Whistle for rest break  
Water used (Fourth bucket emptied)  
.....  
12:11 Restart work  
12:28 Water used  
12:41 Whistle for end of work  
Deminer has reached 300cm

4 buckets of water used; 1.9 square metres cleared; 1 GYATA mine discovered  
[A total of 209 minutes work was recorded, - approx 35 inactive time]

**Trial 7: Lanes 3 and 4:** 11<sup>th</sup> November, NPA Team

**Monitor:** Manuel R. Django

**Deminer:** Joao Horacio

**Section Commander:** Nuno Satar

06:57 Start at 300cm  
07:05 **MINE** discovered, Type 72 at 1cm, (310,80), No damage recorded [AVS: confirmed]  
07:16 Water used  
07:20 **MINE** discovered, GYATA at 12cm, (360, 10), No damage recorded [AVS: confirmed]  
[AVS, top of mine was completely uncovered, sides had to be excavated to allow removal:  
downward pressure could have been heavily applied without leaving evidence.]  
07:25 Restart work after mine removal  
07:27 Whistle for rest break  
Water used  
.....  
07:46 Restart work  
08:16 Whistle for rest break  
Water used (First large bucket emptied)  
.....  
08:36 Restart work  
09:05 Water used (Second large bucket emptied)  
09:06 Stop for rest break  
.....  
09:26 Stop for rest break  
09:37 Fourth square metre completed  
09:42 Water used  
09:56 Stop for rest break  
Water used (Third bucket emptied)  
.....  
11:19 Restart work (after delay for rain)  
11:38 Water used  
11:51 Stop for rest break  
.....  
12:06 Restart work  
12:36 Stop for rest break  
.....  
12:51 Restart work  
13:09 Lane 3 completed, Five square metres cleared  
Move tools and equipment to start of Lane 4  
13:15 Water used on Lane 4  
13:18 Deminer used mattock to start to make a base-trench.  
13:21 Stop work

Manual demining systems – comparative trials: Mozambique 2004.

Two square metres cleared: 2 mines found, 1 GYATA and one Type 72

3 large buckets of water used.

[A total of 212 minutes work was recorded, - approx 35 minutes inactive time]

Editorial note: Django's record of start and finish times does not match others over the same period who reacted to the same whistle.

### **Trial 8: Enxada excavation:**

The trial involved area-excavation (no metal-detection) using the ADP tools and an enxada (mattock). The deminers involved had been trained in the method by an ADP staff trainer who was familiar with the HALO Trust method used in Mozambique.

In the 10 metre test area (comprising two five metre long lanes), 8 targets had been concealed, four Type-72 surrogates and 4 GYATA surrogates. "Natural" fragment contamination was removed from the surface, but not from sub-surface sources. No fragments were deliberately added. No metal-detector was used.

### **Trial 8: Lanes 1 and 2:** 9<sup>th</sup> November

**Monitor:** Paulino Tule Gove

**Deminer:** Januario Justino Mindo

**Section Commander:** Dionisio Chaka

The Deminer located seven of the eight mines concealed in the area. The missed mine was at the extreme edge of the lane and his failure to maintain straight edges to the lane resulted in it being missed. The excavation method included no out-of-lane overlap, and the QA failed to spot the deviation from the line. However, if the area had been extended by an adjacent lane, the method required than lanes be joined all along their sides and so the mine should have been located at the next pass. The deminer did not consider this a missed mine.

One mine was entirely undamaged on recovery. Five had damage on the side. One Type 72 had deep cuts through the bottom edge (which may have pushed the mine upward in the ground and caused a detonation, but this is thought unlikely). A GYATA had been struck on the top with a 12mm deep cut into the wood and it is believed that this mine would certainly have detonated.

The deminer worked a recorded 309 minutes in the area (-16), giving him an average rate of advance of approximately a metre every 30 minutes.

07:50 Whistle to start work

07:55 Self preparation

07:56 One bucket of water used

07:58 Three litres of water used

07:59 Three litres of water used

08:00 Start from 0cm

08:02 1 litre water used

08:09 Three litres used

**MINE** located, Type 72, (30, 05), bottom edge damaged [AVS: confirmed: the damage chopped through the bottom of the mine, but was unlikely to have caused an initiation.]

08:14 2 litres water used

08:20 Whistle for rest break

.....

08:40 Whistle to start work

08:43 One square metre completed

08:52 9 litres water used

09:00 2 litres used

09:06 Second square metre completed

09:08 **MINE** located, Type 72, (225, 95), No damage [AVS: confirmed]

09:10 Whistle for rest break

.....

09:30 Whistle to start work  
09:43 Three litres of water used  
09:44 10 litres of water used  
09:50 Third square metre completed  
09:52 2 litres of water used  
09:58 2 litres of water used  
10:00 Whistle for rest break

.....

10:50 Whistle to start work  
11:05 **MINE** located, GYATA (370, 95), white scratch on side [AVS: confirmed]  
11:10 Fourth square metre completed  
11:14 **MINE** located, GYATA (410, 60), white scratch on side [AVS: confirmed]  
11:20 Whistle for rest break

.....

11:40 Whistle to start work  
11:43 Late arrival of drinking water  
11:45 Deminer in lane, 6 litres of water used  
11:50 3 litres of water used  
12:06 Deminer finishes first five metre lane (Lane 1)  
12:08 Deminer starts preparing start trench for Lane 2  
12:10 Whistle for rest break

.....

12:30 Whistle to start work  
12:33 8 litres of water used  
12:36 1 litre of water used  
12:38 2 litres of water used  
12:48 3 litres of water used  
12:50 5 litres of water used  
12:51 5 litres of water used  
12:52 Deminer advances past start point of Lane 2  
13:00 Whistle for end of work

Paulino's calculations: Mines located: 2 Type 72, 2 x GYATA

Area cleared: 5 metres in Lane 1, 35cm in Lane 2

Quantity of water used: 84 litres

[Hours worked: 180 minutes (-5)]

**Trial 8: Lanes 1 and 2:** 10<sup>th</sup> November

**Monitor:** Paulino Tule Gove

**Deminer:** Januario Justino Mindo

**Section Commander:** Dionisio Chaka

06:42 Whistle to start work  
Deminer starts to work

06:49 3 litres of water used

07:00 First square metre (Lane 2) completed

07:02 **MINE** located, Type 72, (110, 20), scratched on side [AVS: confirmed]

07:05 3 litres of water used

07:10 Whistle for rest break

.....

07:30 Whistle to restart work

07:31 Deminer starts work in lane  
8 litres of water used

07:35 2 litres of water used

07:45 Second square metre completed

07:52 4 litres of water used

07:56 **MINE** located, GYATA (220, 20), side damage [AVS: confirmed]

08:00 Whistle for rest break

.....

08:20 Whistle to restart work

08:23 Deminer restarts in lane

08:32 3 litres of water used

08:40 2 litres of water used

08:45 Third square metre completed

08:51 Whistle for rest break

.....

09:10 Whistle to restart work

09:14 Deminer restarts work in lane

09:23 3 litres of water used

09:30 8 litres of water used

09:32 Fourth square metre completed

09:33 **MINE** located, GYATA (450, 70), : [severe impact on top, cutting wood to 12mm deep: note: this mine was from this trial, but may have been one of the other GYATAs because the top damage was not noted until later. This mine has no side damage, and so is identified by inference, but labelled as Lane 1.]

09:40 Whistle for rest break

.....

10:30 Whistle to restart work

10:33 Deminer in lane and working

10:35 20 litres of water used

10:40 Lane 2 completed.

Paulino's calculations:

Mines located: 2 GYATA, 1 Type 72. 1 Type 72 was missed

Metres cleared in the day: 4.35 [sic] (4.65)

Quantity of water used: 59 litres

[AVS: Paulino calculates 8 litres of water to a bucket, so 7 and 1/3 buckets]

[AVS: 129 minutes work, - 11 delay starting.]

### **Trial 8: Lanes 3 and 4:** 9<sup>th</sup> November, ADP Team 2

**Monitor:** Paulino Tule Gove

**Deminer:** Julio Ernesto Wache

**Section Commander:** Dionisio Chaka

All eight mines in lanes 3 and 4 were located during the trial. Four mines were recovered undamaged. Two mines had light impact damage on the sides. One GYATA had been struck on the top corner in a manner that was likely to have initiated the mine (the GYATA's pressure plate extends to the edge of the top surface). One Type 72 had been broken into two by a heavy impact on the top corner, extending 1.5cm onto the top of the mine. This blow could have resulted in a detonation.

The deminer worked in the area for a recorded 375 minutes (-13) and so progressed at a rate of one metre every 37.5 minutes

07:50 Whistle to start work

07:55 Two buckets of water used

08:04 Advances past start of Lane 3

08:11 **MINE** located, GYATA (20, 60), no damage [AVS: confirmed]

08:20 Whistle for rest break

.....

08:40 Whistle to start work

08:42 Deminer goes to get water [usually brought by Section Commander]

08:44 Two buckets of water used

09:04 5 litres water used

09:10 **MINE** located, Type 72 (70, 80) damaged [photographed] [AVS: Mine is broken in two, held together by latex top caused by heavy cut from above extending 1.5cm across the top of the mine]

Stop for rest break

.....

09:30 Whistle to start work

09:33 3 litres of water used

09:43 First square metre completed

Two litres of water used

09:59 8 litres of water used

10:00 Whistle for rest break

.....

10:50 Whistle to start work  
10:52 5 litres of water used  
11:11 7 litres of water used  
11:18 8 litres of water used  
11:20 **MINE** located, Type 72 (195, 05), Top corner lightly damaged [AVS: confirmed: unlikely to have caused initiation of this mine type]  
Stop for rest break

.....

11:40 Whistle to start work  
11:42 5 litres of water used  
11:48 Second square metre completed  
11:54 5 litres of water used  
12:03 Deminer goes to collect water  
12:05 Two buckets of water used  
12:10 Whistle for rest break

.....

12:30 Whistle to restart work  
12:32 5 litres of water used  
12:41 8 litres of water used  
12:44 8 litres of water used  
12:47 Deminer left area to urinate  
12:49 Deminer returns to area  
12:50 7 litres of water used  
12:51 Third square metre completed  
12:59 7 litres of water used  
13:00 Whistle to stop work

Paulino's calculations: Mine located: 2 x Type 72, 1 x GYATA; 3.3 square metres cleared  
125 litres of water used.

[180 minutes work recorded, -2 recorded for slow start]

### **Trial 8: Lanes 3 and 4: 10<sup>th</sup> November**

**Monitor:** Paulino Tule Gove

**Deminer:** Julio Ernesto Wache

**Section Commander:** Dionisio Chaka

06:42 Whistle to start work  
06:43 Deminer starts to work  
06:55 Fourth square metre (Lane 3) completed  
06:56 5 litres of water used

07:10 Whistle for rest break  
.....  
07:30 Whistle to restart work  
07:31 Deminer starts work in lane  
8 litres of water used  
07:40 **MINE** located, Type 72, (495, 4?), no damage [AVS: confirmed]  
07:47 Fifth square metre completed (all of Lane 3)  
07:48 Preparing area at start of Lane 4  
07:51 24 litres of water used  
08:00 Whistle for rest break  
.....  
08:20 Whistle to restart work  
08:23 Deminer restarts in lane  
08:24 Deminer advances past start line of Lane 4  
08:32 2 litres of water used  
08:34 **MINE** located, Type 72 (40, 50), small scratch on side (bottom) [AVS: damaged paint only: confirmed]  
08:51 Whistle for rest break  
.....  
09:10 Whistle to restart work  
09:13 Deminer restarts work in lane  
09:20 First square metre (Lane 4) completed  
09:25 **MINE** located, GYATA (125, 70), [AVS: impact, penetrating paint, exposing wood on top corner; could have initiated this type of mine]  
09:27 2 litres of water used  
09:31 5 litres of water used  
09:36 5 litres of water used  
09:40 Whistle for rest break  
.....  
10:30 Whistle to restart work  
10:31 Deminer in lane and working  
10:38 Second square metre completed  
10:50 9 litres of water used  
11:00 Whistle for rest break  
.....  
11:20 Whistle to restart work  
11:22 Deminer in lane and restarting work  
11:27 Third square metre completed  
11:33 **MINE** located, GYATA (305, 30), no damage [AVS: confirmed]  
11:35 16 litres of water used

Manual demining systems – comparative trials: Mozambique 2004.

11:44 20 litres of water used

11:51 Whistle for rest break

.....

12:10 Whistle to restart work

12:20 Fourth square metre completed

12:40 Whistle for end of day's work

Paulino's calculations: Area cleared, Lane 3 – 40sq cm, Lane 4 – 450sq cm

Mines found: Lane 3: 1 Type 72, Lane 4: 2 GYATA and 1 TYPE 72

120 litres of water used

[180 minutes work recorded, - 11 minutes recorded for slow start]

### **Trial 8: Lanes 3 and 4:** 11<sup>th</sup> November

**Monitor:** Paulino Tule Gove

**Deminer:** Julio Ernesto Wache

**Section Commander:** Dionisio Chaka

06:56 Whistle to start work

Deminer starts work in Lane 4

06:57 8 litres of water used

07:08 **MINE** located, Type 72 (455, 02), No damage [AVS: confirmed]

07:11 Lane 4 completed

Paulino's calculations: 0.60sq metres cleared: 1 Type 72 mine found

8 litres of water used.

[AVS: Paulino calculates 8 litres of water to a bucket]

[15 minutes work recorded]

### **Trial 9: prodding**

This was a “control” trial designed solely to determine the depth of clearance that could have been achieved in the ground used for these trials. In both trial areas, a single square metre was prepared with concealed targets (Type 72s at depths of 4, 6, and 8cm). The deminers prodded over the area using a prepared guide stick for 1” spacing. Numbers of prod insertions were counted and at approximately every 50 insertions, a measurement of the prod depth and angle was made.

Type 72 surrogate mines were concealed at 4, 6 and 8cm in both areas. One deminer found the two mines at 4 and 6cm. One deminer found only the mine at 6cm. Damage was found on the top of all discovered mines. The remaining mines were recovered later but in an uncontrolled way. All recovered mines were badly damaged on the top, but this may have occurred during recovery.

There was sustained heavy rain between the two stages of the trial: this affected ease of ground penetration.

Before the rain, the average penetration lengths were 6.8cm and 12.9cm: the lowest penetration were 6cm and 9cm. Guaranteed coverage to a depth of 3 and 4.5cm was achieved. Both deminers missed a mine at 8cm and one (the one prodding with deeper penetrations) missed a mine at 4cm. The deminer only prodding to a guaranteed depth of 3cm located the mine at 4cm after prodding onto its top.

After the rain, the deminer in lane one increased his average penetration from 6cm to 9cm. The deminer in Area 2 increased his average penetration from 12.9 to 17.5cm. Allowing for the different technique used (rotating prodder yielding an average 3cm increase in penetration) the average increase caused by rain-water was: Area 1: none, Area 2: 2.4cm.

### **Trial 9: Lane 1, 12<sup>th</sup> November, ADP Team 1**

**Monitor:** Manuel R. Django

**Deminer:** Carlos Tembe

**Section Commander:** Laice

Monitor counted prod insertions and measured depths and angles. The tool was prepared with a scale drawn onto it.

300 insertions [progress was slowed by two excavations revealing nothing]

30°, 7cm

30°, 6cm

20°, 7cm

30°, 8cm

30°, 7cm

30°, 6cm

### **Trial 9: Lane 1, 15<sup>th</sup> November, ADP Team 1**

**Monitor:** Manuel R. Django

**Deminer:** Carlos Tembe

**Section Commander:** Laice

The weekend of the 13<sup>th</sup>/14<sup>th</sup> had included heavy rain and the ground was considerably softened – as illustrated by the increased penetration achieved. An increase in penetration was also achieved by instructing the deminers to rotate the prod blade by 360° at the end of an insertion, then press again. This allowed the low-friction design to operate and led to a measured increase in penetration of 3 to 5cm each time.

600 insertions

Manual demining systems – comparative trials: Mozambique 2004.

40°, 10cm

30°, 9cm

30°, 11cm

30°, 12cm

Starts excavation that leads to Type 72 mine (40mm to top)

Evidence of one prodder strike on top of mine

30°, 10cm

30°, 14cm

30°, 13cm

40°, 11cm

30°, 12cm

30°, 15cm

30°, 20cm

30°, 18cm

Starts excavation that leads to discovery of Type 72 mine (60mm to top)

**Trial 9: Lane 2**, 12<sup>th</sup> November, ADP Team 1

**Monitor:** Mate Gaal

**Deminer:** Helder Martins Afido

**Section Commander:** Fernando Laice

Monitor counted prod insertions and measured depths and angles. The tool was prepared with a scale drawn onto it.

550 insertions

20°, 10cm

20°, 9cm

30°, 10cm

30°, 7cm

25°, 8cm

25°, 8cm

30°, 1cm [Following surface excavation]

30°, 7cm

15°, 10cm

30°, 12cm

35°, 9cm

**Trial 9: Lane 2**, 15<sup>th</sup> November, ADP Team 1

**Monitor:** Mate Gaal

**Deminer:** Helder Martins Afido

**Section Commander:** Fernando Laice

The weekend of the 13<sup>th</sup>/14<sup>th</sup> had included heavy rain and the ground was considerably softened – as illustrated by the increased penetration achieved. An increase in penetration was also achieved by instructing the deminers to rotate the prod blade by 360° at the end of an insertion, then press again. This allowed the low-friction design to operate and led to a measured increase in penetration of 3 to 5cm each time. The increase was measured by noting penetration after the rotation.

30°, 15cm

Deminer discovered a mine by accident while investigating another item (stone). The mine had been damaged on the top by the prodder.

40°, 17cm

30°, 20cm

30°, 18cm

30°, 19cm

30°, 16cm

After 300 insertions the base stick was between 90 and 95cms from the start point. The deminer had made 23 advances. The average advance of the base stick was by 4cm

## **Annex C: Debriefing of Deminers and Section-Commanders**

The following Questions formed the core of the debriefings.

Questions were asked according to what was appropriate. New questions were introduced when appropriate. Interviews were always conducted by two Trial monitors with the same interpreter (Paulino Tule Gove).

1. Do you think that this method would be safe for you to use in a real minefield?
2. Would it be likely to make you have an accident in a minefield?
3. Do you think that the method was thorough and that you left no mines behind in the lanes?
4. [If the deminer/section-commander missed mines, tell them, then] – why do you think you missed mines?
5. For the deminer, were you as comfortable as you usually are when you worked?
6. Was the work harder than the normal ADP method? If so, why?
7. Do you think it will be quicker in a real minefield than the normal ADP method?
8. Can they suggest any way that would improve this method?
9. If they were working in different conditions/minefields, would the method be better or worse?  
[For example, on soft ground, or among trees, on rocks or in ditches/canals.]
10. Do you think that you would have been faster/more thorough if you had more practice with the method?
11. Did you see any signs on the ground indicating where the mines were located?
12. Did you use water? [Did it make the work easier/ why not?]

The questions were sometimes answered (and asked) out of sequence because of the informal nature of the debrief sessions – and occasionally additional questions were asked.

A debriefing was not conducted after Trial 4, which had been organised by BAM.

## **Trial 1: Standard Metal-detector clearance**

**Interviewers:** Mate Gaal; Andy Smith

**Deminer:** Fernando Laice (Section Commander; deminer 1996-98, now Platoon 2iC)

1. Do you think that this method would be safe for you to use in a real minefield?  
*Yes, but it depends on the detector.*
2. Would it be likely to make you have an accident in a minefield?  
*If the deminer keeps to procedures and concentrates, it is safe.*
3. Do you think that the method was thorough and that you left no mines behind?  
*Yes.*
4. [If the deminer/section-commander missed mines, tell them, then] – why do you think you missed mines?  
*Mines can be missed because of low morale, comfort or lack of social satisfaction in terms of money. Money problems cause family worries*
5. Why were some mines found to have been damaged on the top when they were recovered?
6. For the deminer, were you as comfortable as you usually are when you worked? If not, describe the discomfort (i.e., to knees, back, arms, shoulders, etc)  
*Yes, the deminers were comfortable. The breaks were good and the Section Commander helped to build concentration during the breaks.*
7. Was the work harder than the normal ADP method? If so, why?  
*[Not asked, it was the normal ADP method.]*
8. Do you think it will be quicker in a real minefield than the normal ADP method?  
*[Not asked, it was the normal ADP method.]*
9. Can they suggest any way that would improve this method?  
*The use of magnets and the some new detectors.*
10. If they were working in different conditions/minefields, would the method be better or worse?  
*It could be complicated by mineralised ground, mines under rocks, etc.*
11. Do you think that you would have been faster/more thorough if you had more practice with the method?  
*Yes, with refresher training.*
12. Did you see any signs on the ground indicating where the mines were located?  
*No.*

**Interviewers:** Mate Gaal; Andy Smith

**Deminer:** Carlos Tembe (deminer since 1996 with ADP)

1. Do you think that this method would be safe for you to use in a real minefield?  
*Yes, the Minelab metal detector makes me feel safe..*
2. Would it be likely to make you have an accident in a minefield?  
*If the detector is tuned correctly and has no detector faults, and correct SOPs are followed.*
3. Do you think that the method was thorough and that you left no mines behind?

No.

4. [If the deminer/section-commander missed mines, tell them, then] – why do you think you missed mines?
5. Why were some mines found to have been damaged on the top when they were recovered?
6. For the deminer, were you as comfortable as you usually are when you worked? If not, describe the discomfort (i.e., to knees, back, arms, shoulders, etc)  
*[Not asked, it was the normal ADP method.]*
7. Was the work harder than the normal ADP method? If so, why?  
*[Not asked, it was the normal ADP method.]*
8. Do you think it will be quicker in a real minefield than the normal ADP method?  
*[Not asked, it was the normal ADP method.]*
9. Can they suggest any way that would improve this method?  
*Periodic maintenance of the detectors could help. The use of a trowel magnet with the magnet in the centre of the trowel would be good and allow left or right handed use.*
10. If they were working in different conditions/minefields, would the method be better or worse?  
*Hard on rocky ground where mines may be under magnetic rocks and it can be hard to tune the detector and it can make excessive signals.*
11. Do you think that you would have been faster/more thorough if you had more practice with the method?  
*Yes, with more training.*
12. Did you see any signs on the ground indicating where the mines were located?  
No.

**Interviewers:** Mate Gaal; Andy Smith

**Deminer:** Helder Martins Afido (deminer since 1994 with ADP)

1. Do you think that this method would be safe for you to use in a real minefield?  
Yes.
2. Would it be likely to make you have an accident in a minefield?  
*Experience says no.*
3. Do you think that the method was thorough and that you left no mines behind?  
*Detectors sometimes miss weak signals, find them at other times.*
4. [If the deminer/section-commander missed mines, tell them, then] – why do you think you missed mines?
5. Why were some mines found to have been damaged on the top when they were recovered?
6. For the deminer, were you as comfortable as you usually are when you worked? If not, describe the discomfort (i.e., to knees, back, arms, shoulders, etc)  
*[Not asked, it was the normal ADP method.]*
7. Was the work harder than the normal ADP method? If so, why?  
*[Not asked, it was the normal ADP method.]*

8. Do you think it will be quicker in a real minefield than the normal ADP method?  
*[Not asked, it was the normal ADP method.]*
9. Can they suggest any way that would improve this method?  
*The use of a trowel magnet with the magnet in the centre of the trowel. The detectors are tired and it would be safer if they were replaced.*
10. If they were working in different conditions/minefields, would the method be better or worse?  
*Easier in soft or rocky ground. I can recognise the difference between a signal from rock and a signal from metal.*
11. Do you think that you would have been faster/more thorough if you had more practice with the method?  
*Not necessary. The Platoon Commander's briefings cover safety. We only need refresher training when we have new equipment.*
12. Did you see any signs on the ground indicating where the mines were located?  
*No.*

## **Trial 2: Metal-detector clearance with magnetic hand-tool**

**Interviewers:** Mate Gaal; Neville Goulton

**Deminer:** Dionisio Joachim Chaka (Section Commander)

1. Do you think the method with the magnet trowel is safe to use in a real minefield?  
*Very useful in combination with metal detector, helps to remove surface metal and fragments Saves time.*  
Is there anything dangerous about using the magnet trowel?  
*No different from using trowel without the magnet but increases speed.*
2. Do you think that the method was thorough and you left no mines behind in the lanes?  
*Yes, very good method, but no help in finding mines. Deep mines are just as difficult as in standard method.*
3. Did the method cause any extra discomfort when used? Was it tiring or did it strain your arms, legs, etc. more than usual?  
*Better, trowel without magnet is more tiring because you have to work harder to find all the fragments.*
4. Do you think this method will be quicker than the normal ADP method in a real minefield?  
*In a minefield this method will be faster, if there is metal in the minefield (not all minefields are heavily contaminated with metal).*  
How long would an area that usually takes 30min to clear take with this method?  
*Estimate 30min work could be done in 15min.*
5. How could the magnet trowel be improved?  
*Make the magnet wider, length is OK.*
6. Would working in minefields with different conditions (example; rocky, soft soil, ditches, etc) cause any problems using the magnet trowel?  
*No problem.*
7. Do you think that you would work better with more training?  
*No requirement. We are experienced with the standard trowel and differences are minimal.*
8. Did you see any signs on the ground that gave you a clue to where the mines were located?  
*No. Metal on surface could sometimes be seen but mine locations were not identifiable.*

**Interviewers:** Mate Gaal; Neville Goulton

**Deminer:** Januario Justino Mindo

1. Do you think the method with the magnet trowel is safe to use in a real minefield?  
*Yes.*  
Is there anything dangerous about using the magnet trowel?  
*No, safer because it makes the job easier by increasing speed.*
2. Do you think that the method was thorough and you left no mines behind in the lanes?  
*Mines can be missed as with standard method, but fragments are collected.*  
Why are mines missed?  
*Missed due to depth.*
3. Did the method cause any extra discomfort when used? Was it tiring or did it strain your arms, legs, etc. more than usual?  
*More comfortable. It is tiring when kneeling, with magnet trowel the time spent kneeling is less.*
4. Do you think this method will be quicker than the normal ADP method in a real minefield?  
*Speed is relative. Speed depends on how the deminer feels when he gets up in the morning.*  
How long would an area that usually takes 30min to clear take with this method?

*If I wake up feeling OK I guess 30min task could be completed in 20min with the magnet trowel.*

5. How could the magnet trowel be improved?  
*Make the magnet wider, and longer. (Deminer indicated that he thought the magnet should be located centrally along the trowel blade).*
6. Would working in minefields with different conditions (example; rocky, soft soil, ditches, etc) cause any problems using the magnet trowel?  
*No difference.*
7. Do you think that you would work better with more training?  
*Yes more training could speed us up, but not much practice is needed. Demining is in our blood. We are happy with your introduction of the magnet trowel.*
8. Did you see any signs on the ground that gave you a clue to where the mines were located?  
*No.*
9. Did you use water? [Did it make the work easier/ why not?]  
*Yes, water made excavating easier.*
10. Do you prefer the magnet trowel method?  
*Yes.*

**Interviewers:** Mate Gaal; Neville Goulton

**Deminer:** Julio Ernesto Wache

1. Do you think the method with the magnet trowel is safe to use in a real minefield?  
*Yes, no difference to standard ADP method. This method is faster and more flexible.*  
Is there anything dangerous about using the magnet trowel?  
*No.*
2. Do you think that the method was thorough and you left no mines behind in the lanes?  
*The mine can be missed with the metal detector. Magnetic trowel does not discover the mines. It collects the metal.*  
Why are mines missed?  
*Mines missed because they were deep.*
3. Did the method cause any extra discomfort when used? Was it tiring or did it strain your arms, legs, etc. more than usual?  
*Much more comfortable because it accelerated the process*
4. Do you think this method will be quicker than the normal ADP method in a real minefield?  
*Depends on the quantity of metal.*  
How long would an area that usually takes 30min to clear take with this method?  
*Estimate with same quantities as these test lanes 30min work could be done in 10-15min.*
5. How could the magnet trowel be improved?  
*Will have better ideas after some use in real minefields.*
6. Would working in minefields with different conditions (example; rocky, soft soil, ditches, etc) cause any problems using the magnet trowel?  
*No problem.*
7. Do you think that you would work better with more training?  
*No additional requirement.*
8. Did you see any signs on the ground that gave you a clue to where the mines were located?  
*No. I missed mines, maybe because of many metal pieces.*
9. Did you use water? [Did it make the work easier/ why not?]  
*Yes, I used water to make the work easier.*
10. In a real minefield would you choose to use a magnet trowel or a standard trowel?  
*A magnet trowel.*

### **Trial 3: Metal-detector with magnet Brush-rake**

**Interviewers:** Mate Gaal; Andy Smith

**Deminer:** Dionisio Chaka (Section Commander)

1. Do you think that this method would be safe for you to use in a real minefield?  
*Yes, but it needs improvement. The magnet should be wider and closer to the ground. Better spring in the tines might help. The length of the handle is OK and gives security.*
2. Would it be likely to make you have an accident in a minefield?  
*The deminers must be well trained and must cut grass first because of tripwires.*
3. Do you think that the method was thorough and that you left no mines behind?  
*The magnet helps remove metal only.*
4. [If the deminer/section-commander missed mines, tell them, then] – why do you think you missed mines?  
*The metal-detector is not OK. Readings on the same ground can vary. The detectors are tired.*
5. Why were some mines found to have been damaged on the top when they were recovered?  
*Because of the hard ground.*
6. For the deminer, were you as comfortable as you usually are when you worked? If not, describe the discomfort (i.e., to knees, back, arms, shoulders, etc)  
*Yes, the deminers were not tired.*
7. Was the work harder than the normal ADP method? If so, why?
8. Do you think it will be quicker in a real minefield than the normal ADP method?  
*Yes it made it quicker because of the magnet. The rake helped the magnet to work.*
9. Can they suggest any way that would improve this method?  
*Improve the way that the rake-head attaches to the handle.*
10. If they were working in different conditions/minefields, would the method be better or worse?  
*There would be problems in muddy ground.*
11. Do you think that you would have been faster/more thorough if you had more practice with the method?  
*Yes, more training would have been helpful.*
12. Would you prefer the magnet-Brush-rake or the clip-on magnet for a trowel?  
*Prefer to have both tools together.*
13. Did you see any signs on the ground indicating where the mines were located?  
*No.*

**Interviewers:** Mate Gaal; Andy Smith

**Deminer:** Januario Justino Mindo

1. Do you think that this method would be safe for you to use in a real minefield?  
*It is not safe. Some ground is full of thorns, breaking undergrowth and detonating mines.*
2. Would it be likely to make you have an accident in a minefield?

*Could detonate the fuze.*

3. Do you think that the method was thorough and that you left no mines behind?  
Yes.
4. Did clearing the fragments help you to find the mines?  
Yes.
5. [If the deminer/section-commander missed mines, tell them, then] – why do you think you missed mines?  
*The mines were too deep.*
6. Did you ignore detector readings that were very small?  
*Yes. The detectors are unreliable and switch off on their own.*
7. For the deminer, were you as comfortable as you usually are when you worked?  
If not, describe the discomfort (i.e., to knees, back, arms, shoulders, etc)  
*More comfortable because working standing.*
8. Was the work harder than the normal ADP method? If so, why?
9. Do you think it will be quicker in a real minefield than the normal ADP method?  
*Yes but that depends on the terrain.*
10. Can they suggest any way that would improve this method?  
*Magnet should be wider and closer t the ground. The tines should be made more springy. The way to attach the head to the handle should be improved.*
11. If they were working in different conditions/minefields, would the method be better or worse?  
*Yes and no. That would need to be assessed.*
12. Do you think that you would have been faster/more thorough if you had more practice with the method?  
Yes.
13. Would you prefer the magnet-Brush-rake or the clip-on magnet for a trowel?  
*The clip-on magnet for the trowel is safer.*
14. Did you see any signs on the ground indicating where the mines were located?  
No.

**Interviewers:** Mate Gaal; Andy Smith

**Deminer:** Julio Ernesto Wache

1. Do you think that this method would be safe for you to use in a real minefield?  
*That depends on the terrain and vegetation.*
2. Would it be likely to make you have an accident in a minefield?  
*Not is used correctly. If used incorrectly it could.*
3. Do you think that the method was a thorough way of clearing fragments?  
Yes.
4. Did clearing the fragments help you to find the mines?  
*Yes because the rake can also expose shallow mines.*
5. [If the deminer/section-commander missed mines, tell them, then] – why do you think you missed mines?

6. For the deminer, were you as comfortable as you usually are when you worked?  
If not, describe the discomfort (i.e., to knees, back, arms, shoulders, etc)  
*More comfortable, depends on method.*
7. Was the work harder than the normal ADP method? If so, why?
8. Do you think it will be quicker in a real minefield than the normal ADP method?  
*Yes because it collects metal.*
9. Can they suggest any way that would improve this method?  
*Magnet should be wider. The way to attach the head to the handle should be improved.*
10. If they were working in different conditions/minefields, would the method be better or worse?  
*Assessment in various condition and with different vegetation is important. Mud, rock or sand should be no problem.*
11. Do you think that you would have been faster/more thorough if you had more practice with the method?  
*Yes.*
12. Would you prefer the magnet-Brush-rake or the clip-on magnet for a trowel?  
*The clip-on magnet for the trowel. To have both would be ideal.*
13. Did you see any signs on the ground indicating where the mines were located?  
*No.*

## **Trial 5: REDS system**

**Interviewers:** Mate Gaal; Andy Smith

**Deminer:** Fernando Laice (Section Commander; deminer 1996-98, now Platoon 2iC)

1. Do you think that this method would be safe for you to use in a real minefield?  
*In hard ground, no.*
2. Would it be likely to make you have an accident in a minefield?  
*Yes in hard ground it is very dangerous because the Harrow rake will set off mines. No problem with the brush-rake.*
3. Do you think that the method was thorough and that you left no mines behind?  
*Yes, with this method it is not possible to leave mines behind.*
4. [If the deminer/section-commander missed mines, tell them, then] – why do you think you missed mines?
5. Why were some mines found to have been damaged on the top when they were recovered?
6. For the deminer, were you as comfortable as you usually are when you worked? If not, describe the discomfort (i.e., to knees, back, arms, shoulders, etc)  
*No, the deminers had backache on hard ground because they leaned too far forward and used too much effort.*
7. Was the work harder than the normal ADP method? If so, why?  
*Yes (see above).*
8. Do you think it will be quicker in a real minefield than the normal ADP method?  
*No in hard ground, yes in soft ground.*
9. Can they suggest any way that would improve this method?  
*No. I need more familiarity before I could suggest improvements.*
10. If they were working in different conditions/minefields, would the method be better or worse?  
*It could be safer on soft ground or a beach.*
11. Do you think that you would have been faster/more thorough if you had more practice with the method?  
*Yes, it would have been better with more training.*
12. Did you see any signs on the ground indicating where the mines were located?  
*No.*

**Interviewers:** Mate Gaal; Andy Smith

**Deminer:** Carlos Tembe (deminer since 1996 with ADP)

1. Do you think that this method would be safe for you to use in a real minefield?  
*Yes but depends on type of terrain.*
2. Would it be likely to make you have an accident in a minefield?  
*In hard ground it could be dangerous unless water is used. If you did not follow rules of depth it could cause an accident. It is safe if deminer follows rules.*
3. Do you think that the method was thorough and that you left no mines behind?  
*Yes, seriously cannot leave mines behind.*
4. [If the deminer/section-commander missed mines, tell them, then] – why do you think you missed mines?

5. Why were some mines found to have been damaged on the top when they were recovered?
6. For the deminer, were you as comfortable as you usually are when you worked? If not, describe the discomfort (i.e., to knees, back, arms, shoulders, etc)  
*Harder work on the first day and very tired, but normal after that. Comfortable if following rules.*
7. Was the work harder than the normal ADP method? If so, why?  
*Yes (see above).*
8. Do you think it will be quicker in a real minefield than the normal ADP method?  
*No in hard ground because the spade takes much more earth with each advance. Yes in soft ground.*
9. Can they suggest any way that would improve this method?  
*No. Too much water makes mud and then it is harder to work, but water is needed on hard ground.*
10. If they were working in different conditions/minefields, would the method be better or worse?  
*Soft ground would be faster and easier.*
11. Do you think that you would have been faster/more thorough if you had more practice with the method?  
*Yes.*
12. Did you see any signs on the ground indicating where the mines were located?  
*No.*

**Interviewers:** Mate Gaal; Andy Smith

**Deminer:** Januario Justino Mindo

1. Do you think that this method would be safe for you to use in a real minefield?  
*Yes.*
2. Would it be likely to make you have an accident in a minefield?  
*In hard ground needs much care or could cause an accident.*
3. Do you think that the method was thorough and that you left no mines behind?  
*Yes.*
4. [If the deminer/section-commander missed mines, tell them, then] – why do you think you missed mines?
5. Why were some mines found to have been damaged on the top when they were recovered?
6. For the deminer, were you as comfortable as you usually are when you worked? If not, describe the discomfort (i.e., to knees, back, arms, shoulders, etc)  
*No. Upper arms and lower back both ached.*
7. Was the work harder than the normal ADP method? If so, why?  
*Yes (see above).*
8. Do you think it will be quicker in a real minefield than the normal ADP method?  
*Depends on ground. In hard ground, no. In soft ground, yes.*
9. Can they suggest any way that would improve this method?

*The Brush-rake helped when the mines were shallow. You could add a tine to the Harrow rake to help lift rocks and mines.*

10. If they were working in different conditions/minefields, would the method be better or worse?

*In hard ground the deminer gets more tired and so works unsafely. Pouring water the day before can make it easier.*

11. Do you think that you would have been faster/more thorough if you had more practice with the method?

*Yes.*

12. Did you see any signs on the ground indicating where the mines were located?

*No.*

**Interviewers:** Mate Gaal; Andy Smith

**Deminer:** Helder Martins Afido (deminer since 1994 with ADP)

1. Do you think that this method would be safe for you to use in a real minefield?

*No because the mines in Mozambique could cause an accident, PMN, GYATA, PMN-2.*

2. Would it be likely to make you have an accident in a minefield?

*[See above.]*

3. Do you think that the method was thorough and that you left no mines behind?

*Yes, I am sure.*

4. [If the deminer/section-commander missed mines, tell them, then] – why do you think you missed mines?

5. Why were some mines found to have been damaged on the top when they were recovered?

6. For the deminer, were you as comfortable as you usually are when you worked? If not, describe the discomfort (i.e., to knees, back, arms, shoulders, etc)

*No. Had backache, blisters on hands because the terrain was too hard.*

7. Was the work harder than the normal ADP method? If so, why?

*Yes, a little harder.*

8. Do you think it will be quicker in a real minefield than the normal ADP method?

*Speed depends on deminer flexibility.*

9. Can they suggest any way that would improve this method?

*The Brush rake is better on softer ground. Hand grips on the handles might show where best to hold handle and stop blisters.*

10. If they were working in different conditions/minefields, would the method be better or worse?

*Pouring water the day before makes it easier.*

11. Do you think that you would have been faster/more thorough if you had more practice with the method?

*Yes. There was not enough training to give him confidence.*

12. Did you see any signs on the ground indicating where the mines were located?

*No.*

## **Trial 6: Standard ADP spade excavation**

**Interviewers:** Mate Gaal; Andy Smith

**Deminer:** Fernando Laice (Section Commander; deminer 1996-98, now Platoon 2iC)

1. Do you think that this method would be safe for you to use in a real minefield?  
*Yes, following procedures properly.*
2. Would it be likely to make you have an accident in a minefield?  
*When careless, or lazy to use water.  
Could lack of prodding cause an accident?  
Yes.*
3. Do you think that the method was thorough and that you left no mines behind?  
*Because it goes to deeper than 13cm, yes, and because mines are exposed from the side.*
4. [If the deminer/section-commander missed mines, tell them, then] – why do you think you failed to maintain a clearance depth of 13cm?
5. For the deminer, were you as comfortable as you usually are when you worked? If not, describe the discomfort (i.e., to knees, back, arms, shoulders, etc)  
*The deminers were uncomfortable due to the terrain. On soft ground it is safer.*
6. Do you think it will be quicker in a real minefield than other methods?  
*No. On soft ground it is faster.*
7. Can they suggest any way that would improve this method?  
*No.*
8. If they were working in different conditions/minefields, would the method be better or worse?  
*Soft ground is faster.*
9. Did you see any signs on the ground indicating where the mines were located?  
*No.*

**Interviewers:** Mate Gaal; Andy Smith

**Deminer:** Carlos Tembe (deminer since 1996 with ADP)

1. Do you think that this method would be safe for you to use in a real minefield?  
*In soft ground it is safe. In hard ground needs to use water or can jeopardise life.*
2. Would it be likely to make you have an accident in a minefield?  
*Yes sometimes.*
3. Do you think that the method was thorough and that you left no mines behind?  
*Yes.*
4. [If the deminer/section-commander missed mines, tell them, then] – why do you think you failed to maintain a clearance depth of 13cm?
5. For the deminer, were you as comfortable as you usually are when you worked? If not, describe the discomfort (i.e., to knees, back, arms, shoulders, etc)  
*Tiring when you break rules. Becomes comfortable as you get used to it.*
6. Do you think it will be quicker in a real minefield than other methods?  
*Depends on the ground. Softer ground is quicker.*

7. Can they suggest any way that would improve this method?  
*Use of trowel and spade. Spade is too big, trowel too small. Trowel can be quicker on soft ground. Also using a lot of water. Prod with care and investigate with trowel.*
8. If they were working in different conditions/minefields, would the method be better or worse?  
*Soft ground is faster.*
14. Do you think that you would have been faster/more thorough if you had more practice with the method?  
*Yes, refresher training could have made it easier. By third day your body gets used to it.*
9. Did you see any signs on the ground indicating where the mines were located?  
*No.*

**Interviewers:** Mate Gaal; Andy Smith

**Deminer:** Helder Martins Afido (deminer since 1994 with ADP)

1. Do you think that this method would be safe for you to use in a real minefield?  
*It is safe but in hard ground a combination with the trowel would be safer.*
2. Would it be likely to make you have an accident in a minefield?  
*No.*
3. Do you think that the method was thorough and that you left no mines behind?  
*Yes.*
4. [If the deminer/section-commander missed mines, tell them, then] – why do you think you failed to maintain a clearance depth of 13cm?
5. For the deminer, were you as comfortable as you usually are when you worked? If not, describe the discomfort (i.e., to knees, back, arms, shoulders, etc)  
*Tiring.*
6. Do you think it will be quicker in a real minefield than other methods?  
*Yes, it can be the quickest.*
7. Can they suggest any way that would improve this method?  
*Use of more water would be an improvement. A water trailer is needed.*
8. If they were working in different conditions/minefields, would the method be better or worse?  
*Softer ground is easier because the prodder and the trowel can also be used. In hard ground, only the trowel can be used to assist the spade.*
15. Do you think that you would have been faster/more thorough if you had more practice with the method?  
*No. Briefings provide the training needs.*
9. Did you see any signs on the ground indicating where the mines were located?  
*No. Mines were found from the side by scraping onto them.*

## **Trial 7: NPA short excavator**

**Interviewers:** Mate Gaal; Andy Smith

**Deminer:** Nuno Satar (Section Commander/QA officer)

10. Do you think that this method would be safe for you to use in a real minefield?  
*Yes.*
11. Would it be likely to make you have an accident in a minefield?  
*No, not in terrain like that. Depth not maintained.*
12. Do you think that the method was thorough and that you left no mines behind?  
*Yes.*
13. [If the deminer/section-commander missed mines, tell them, then] – why do you think you failed to maintain a clearance depth of 13cm?  
*This can happen. Normal excavation depth for NPA is 20cm.*
14. For the deminer, were you as comfortable as you usually are when you worked? If not, describe the discomfort (i.e., to knees, back, arms, shoulders, etc)  
*The deminers complained of the hard ground. Better on soft.*
15. Do you think it will be quicker in a real minefield than other methods?  
*It is very safe. Speed does not matter.*
16. Can they suggest any way that would improve this method?  
*No.*
17. If they were working in different conditions/minefields, would the method be better or worse?  
*Soft ground is better. It is better to use more water.*
18. Did you see any signs on the ground indicating where the mines were located?  
*No.*

**Interviewers:** Mate Gaal; Andy Smith

**Deminer:** Joao Horacio (deminer since 1993 with NPA)

1. Do you think that this method would be safe for you to use in a real minefield?  
*Yes, for deminers.*
2. Would it be likely to make you have an accident in a minefield?  
*No, if you keep to procedures there will be no accidents.*
3. Do you think that the method was thorough and that you left no mines behind?  
*Yes, to the depth.*
4. [If the deminer/section-commander missed mines, tell them, then] – why do you think you failed to maintain a clearance depth of 13cm?
5. For the deminer, were you as comfortable as you usually are when you worked? If not, describe the discomfort (i.e., to knees, back, arms, shoulders, etc)  
*It was tiring.*
6. Do you think it will be quicker in a real minefield than other methods?  
*It is not quicker. It is used only in contaminated ground.*
7. Can they suggest any way that would improve this method?

*Combine the method with the use of a metal-detector would be an improvement.*

8. If they were working in different conditions/minefields, would the method be better or worse?

*Hard terrain needs water.*

9. Did you see any signs on the ground indicating where the mines were located?

*No.*

**Interviewers:** Mate Gaal; Andy Smith

**Deminer:** Quito Armando (deminer since 2000 with NPA)

1. Do you think that this method would be safe for you to use in a real minefield?

*Yes.*

2. Would it be likely to make you have an accident in a minefield?

*Yes, if depth is not maintained.*

3. Do you think that the method was thorough and that you left no mines behind?

*Yes.*

4. [If the deminer/section-commander missed mines, tell them, then] – why do you think you failed to maintain a clearance depth of 13cm?

*The depth maintenance depends on the depth that mines are found.*

5. For the deminer, were you as comfortable as you usually are when you worked? If not, describe the discomfort (i.e., to knees, back, arms, shoulders, etc)

*It was tiring but you get used to it.*

6. Do you think it will be quicker in a real minefield than other methods?

*Yes, it is fast.*

7. Can they suggest any way that would improve this method?

*The tool is too short. The handle length should be increased and the blade shape changed to reduce the width.*

8. If they were working in different conditions/minefields, would the method be better or worse?

*Yes, it is not always easier in soft ground. Can be used in stony ground.*

9. Did you see any signs on the ground indicating where the mines were located?

*No.*

## **Trial 8: area excavation with mattock (enxada)**

**Interviewers:** Mate Gaal; Andy Smith

**Deminer:** Dionisio Chaka (Section Commander)

1. Do you think that this method would be safe for you to use in a real minefield?  
*No. The forces applied are too great and make the task dangerous.*
2. Do you think it would have been safer if they did more prodding between excavating?  
*Yes, in softer ground.*
3. Do you think that the method was thorough and that you left no mines behind?  
*If you start the lane at the right depth you will find all the mines, but it is not safe.*
4. [If the deminer/section-commander missed mines, tell them, then] – why do you think you missed mines?  
*The mine was outside the area worked. It would have been found when the next lane was cut.*
5. For the deminer, were you as comfortable as you usually are when you worked? If not, describe the discomfort (i.e., to knees, back, arms, shoulders, etc)  
*Yes, we need more training.*
6. Was the work harder than the normal ADP method? If so, why?  
*Yes, and more dangerous.*
7. Do you think it will be quicker in a real minefield than the normal ADP method?  
*Yes, but more dangerous.*
8. Can they suggest any way that would improve this method?  
*Use it is soft ground with a prodder first.*
9. If they were working in different conditions/minefields, would the method be better or worse?
10. Do you think that you would have been faster/more thorough if you had more practice with the method?  
*Yes, but it could only be used as second best.*
11. Could the tool be improved to make it safer?  
*No. The position of the head is wrong.*
12. Did you see any signs on the ground indicating where the mines were located?  
*No.*

**Interviewers:** Mate Gaal; Andy Smith

**Deminer:** Januario Justino Mindo

1. Do you think that this method would be safe for you to use in a real minefield?  
*No. It needs much force and can detonate mines.*
2. Do you think it would have been safer in softer ground so that it was easier to prod between excavating?  
*No.*
3. Do you think that the method was thorough and that you left no mines behind?  
*Yes, but only to 13cm, not to 20cm depth.*

4. [If the deminer/section-commander missed mines, tell them, then] – why do you think you missed mines?  
*The method is very tiring: possibly missed because tired. I was trying to avoid cutting the marking tape so did not cut right to the edge. The tool makes it difficult to cut a straight edge to the lane.*
5. For the deminer, were you as comfortable as you usually are when you worked? If not, describe the discomfort (i.e., to knees, back, arms, shoulders, etc)  
*No. The method is very tiring.*
6. Was the work harder than the normal ADP method? If so, why?  
*Yes, I prefer the spade.*
7. Do you think it will be quicker in a real minefield than the normal ADP method?  
*Yes, but it is more dangerous.*
8. Can they suggest any way that would improve this method?  
*Use it is soft ground with a prodder first.*
9. Could the tool be improved to make it safer?  
*No.*
10. Could people be trained to use the tool more safely?  
*Perhaps, but there would be daily accidents.*
11. Did you see any signs on the ground indicating where the mines were located?  
*No.*

**Interviewers:** Mate Gaal; Andy Smith

**Deminer:** Julio Ernesto Wache

1. Do you think that this method would be safe for you to use in a real minefield?  
*No. The effort needed is too much. Use more power and you risk breaking mines.*
2. Do you think it would have been safer in softer ground so that it was easier to prod between excavating?  
*Yes, when the use of the prodder is possible. Prodding was not possible in this ground.*
3. Do you think that the method was thorough and that you left no mines behind?  
*Yes, but it is dangerous.*
4. [If the deminer/section-commander missed mines, tell them, then] – why do you think you missed mines?
5. For the deminer, were you as comfortable as you usually are when you worked? If not, describe the discomfort (i.e., to knees, back, arms, shoulders, etc)  
*No. The method is very tiring.*
6. Was the work harder than the normal ADP method? If so, why?  
*Yes, I prefer the spade. I have been trained better with the spade.*
7. Do you think it will be quicker in a real minefield than the normal ADP method?  
*Yes, but it is more dangerous.*
8. Can they suggest any way that would improve this method?  
*A smaller enxada might be better, but smaller would be slower and could not be used in hard ground.*

9. Could the tool be improved to make it safer?
10. Could people be trained to use the tool more safely?  
*No but this depends on donors. If donors want, but its very dangerous.*
11. Did you see any signs on the ground indicating where the mines were located?  
*No.*

## **Annex D: QinetiQ trial report**

### A COMPARATIVE ASSESSMENT OF MANUAL DEMINING TECHNIQUES/TOOLS QINETIQ OBSERVER'S OBSERVATIONS -DRAFT

Neville Goulton, QinetiQ/FST/LDS/TR050221

January 2005

QinetiQ Ltd  
Cody Technology Park  
Farnborough  
Hampshire  
GU14 0LX

Copyright © QinetiQ Ltd 2005

### **Introduction**

QinetiQ was tasked by the Department for International Development to attend a trial of manual demining methods in Mozambique from 1 Nov to 12 Nov 2004. The trial was organised by Andy Smith as part of the Manual Demining Study being carried out by Tim Lardner for the Geneva International Centre for Humanitarian Demining (GICHD) on behalf of the UN MAS.

Neville Goulton, representing QinetiQ, was tasked to observe and assist in the conduct of the trial.

### **Manual Demining Trial**

The Manual Demining Trial was a comparative assessment of manual demining techniques/tools.

#### **Aim**

The aim of the trial was to evaluate the relative efficiency of selected common manual clearance methods.

#### **General**

The trial was conducted in the Advanced Demining Programme's (ADP) test area in Moamba, approximately 40 miles North of Maputo in Southern Mozambique and took place between 1 to 20 November 2004.

Figure 1 - Trial Location [not provided]

The trial was organised by Andy Smith for the GICHD. Participants in the trial were QinetiQ, BAM (Berlin University, Reliability Research Institute), and deminers and QA staff from ADP and Norwegian People's Aid (NPA).

The trial tested complete "systems" including marking, internal QA, techniques, etc. as well as demining techniques. The deminers were supervised by their own supervisors (Section Leaders) to ensure that the systems were executed correctly. Activity was monitored and results recorded by trial monitors. Trial monitors were external observers or ADP QA personnel and were not permitted to instruct or correct deminers.

The "basic" method of manual-demining, i.e. using a metal detector and investigation tools, was compared with other methods/tools. Other methods and tools included were:

- Combining the "basic" method with a magnetic trowel.
- Combining the "basic" method with a magnetic brush rake.
- Various excavation methods used by ADP, NPA and the Halo Trust, which employ spade, trowel and mattock respectively, to excavate without the use of metal detectors.

- The Sri Lanka rake method.

In addition a prodding trial was conducted to determine realistic prodding depths and a detector trial was conducted by BAM to verify their trial methodology.

Ambient weather conditions, speed of coverage, thoroughness of clearance, depth of excavation, damage to targets, and placed metal removed, were all recorded. More subjectively, the opinions of the deminers were gathered in terms of their confidence in the method and their comfort when carrying out the required procedures, fatigue, etc.

It was recognised that as the trial was being conducted in one place, at one time and with a small set of experienced deminers, the “Findings” may not apply broadly.

### Trial Area

All the trial mine lanes were within one trial area in order to ensure that common conditions were used for each test - with targets and metal scrap positioned and mapped, and undergrowth removed before the trials start. The existing contamination of the areas was unknown. The area is believed to have a naturally high level of electromagnetic disturbance. Rain was anticipated at night during the trials, but only occurred infrequently.

Figure 2, below, shows the trial area layout. Each test area comprised four separate 5 metre mine lanes (separated by one metre gaps).

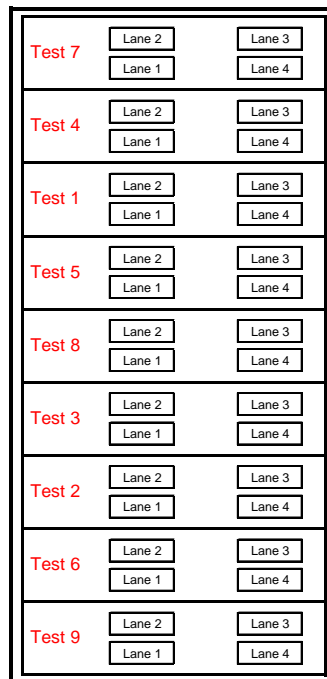

Figure 2 - Trial Lane Layout

### Targets

Surrogate mines of the right size and colour were produced to represent GYATA-64s and Type 72 blast mines. Their placement took place in the week before the trials. The targets were laid to a predefined plan designed by BAM to ensure an even dispersion of mines that was not predictable. Targets were buried shallow (1cm to the top of the mine) and deep (12cm to the top of the mine). The clearance depth required of the deminers was Mozambique's minimum standard of 13cm. The tops of the surrogate mines were coated with latex layer over a painted surface in an attempt to record any damage/pressure occurring during detection and excavation of the mines.

In addition to the target mines, scrap fragments were placed in mapped positions. The "scrap" had been collected for the trials from real minefields by ADP. Scrap was positioned flush with surface, and at 1 cm and 2cm depth and included a defined proportion of non-ferrous material.

Figure 3 - Scrap metal [not provided]

## **Procedure**

Each test was conducted by a team of two deminers and a section leader supervising both deminers. The section leader's responsibilities were the same as in real clearance operations to direct and supervise the two deminers to ensure the procedures and standards were maintained throughout the test and to conduct internal Quality Assurance (QA). During each test both deminers each cleared two of the lanes. Therefore for each test procedure four lanes were cleared by two deminers.

During the tests trial monitors recorded the results and activities each of the tests. The monitors were observers and recorders only and were not permitted to direct or correct the deminers.

## **Tests**

### **Test 1 - Standard method – ADP Demining Team 1**

Ground Compensating (GC) Minelab metal detectors and ADP investigation tools (trowel, prodders, etc.) were used to clear the test areas by two ADP deminers under the supervision of a Section Leader. The ADP "long" tools were used throughout the trials to ensure that all tools used by ADP were identical. This activity is the main "control" against which the other tests were measured.

### **Test 2 - Standard plus magnet on trowel – ADP Demining Team 2**

GC Minelab metal detectors and the ADP investigation tools with a magnet system attached to the trowel were used to clear the test areas. The magnet trowel is an adaptation of CMAC Cambodia's method with the magnet attached along one edge of the trowel. When a signal is encountered, the magnet trowel is used to remove any magnetic surface scrap that is present. If that fails, the unmagnetised edge of the trowel is used to lightly scrape the ground surface and the spoil rolled over the magnetic edge and off the trowel.

### **Test 3 - Standard plus Brush-Rake-Magnet (BRM) – ADP Demining Team 2**

GC Minelab metal detectors were used along with a BRM (the un-modified brush rake is a 2 metre long tool that has been used successfully in Kosovo and Sri Lanka for similar purposes). When there is a signal, the ground area is swept with the BRM and the attached magnet picks up magnetic fragments. The BRM was used with the detector and other long ADP excavation tools (with no magnets attached).

### **Test 4 - Detector alone**

This was the BAM detector trial in which, the GC detector alone was used. BAM wanted to determine how closely the markers are placed to the targets (checking pinpointing reality). Initially target indicators were placed and locations recorded when detections were made. The indicators were subsequently removed and the targets re-detected and exposed to measure how accurately the original markers had been placed.

### **Test 5 - The REDS rake system**

The REDS rake system used by NPA in Sri Lanka was used to try to clear the test areas. (The method used was as taught by an NPA supervisor, who flew in from Sri Lanka for the purpose, and no magnets were used). This technique is an NPA system of excavation that is sometimes used on very hard ground. Two deminers worked under supervision from the NPA trainer.

### **Test 6 - Standard ADP excavation**

The ADP excavation only system using a spade and investigation tools was used to try to clear the test areas. No metal detectors or magnetic attachments were used. Comparison with the ADP SOP will later be made. The method is expected to be thorough, but slow. Depth may vary.

### **Test 7 - Standard NPA (Mozambique) Excavation Method**

The NPA Mozambique excavation system was used to try to clear the test areas by two NPA deminers under the supervision of an NPA Section Leader. This method uses no metal detectors but clears by the complete excavation of the lane using standard handtools. Comparison with ADP SOP will later be made. NPA Mozambique sent two deminers and a Section Leader to take part in the trials – using the complete system (including marking) with which they were accustomed.

### **Test 8 - Standard Mattock excavation**

The Enxada (Mattock) system was used to try to clear the trial areas by two ADP deminers under the supervision of a Section Leader. Comparison with ADP SOP will later be made. ADP do not use this tool. Two ADP deminers and a Section Leader were trained in the Mattock system by one of the English speaking ADP QA men prior to the start of the trials. The trainer formerly worked as a field supervisor with a group that did use Mattocks.

### **Test 9 - Prodding**

In a "control test", ADP (low-friction) prodders were used alone to determine the actual depth that could be prodded on that trial area. This was done by two deminers over a smaller area with targets placed at depths straddling that which was thought possible. This test was scheduled early to allow time for a second area to be prepared if the deminers achieved depths greater than expected.

## **Constraints**

The QinetiQ observer was only available in for the trial for the period 1 – 12 Nov. He did not therefore observe all of the tests. The tests that were observed and are commented on in this report are; Tests 1, 2, 3, 6, 7 & 8.

The ADP deminers were all experienced, however their experience, capabilities and attitude to the trial varied. Time did not allow all deminers to conduct each test, therefore no account has been taken of possible variations in clearance rates due to the technique or attitude of the deminer. Additional trials are required to confirm the effect that the deminer has on overall clearance rates.

No account has been taken of the additional caution that may be intrinsic to demining operations when working in live minefields or the effect that this may have on the deminers speed. It is difficult to see how this factor could be safely integrated into a trial situation as by its vary nature a physical hazard that might harm the deminer would have to be introduced. Furthermore the deminers' perception of danger when working in a live minefield will differ widely depending on the combination of a large range of variables, including; the deminer, the mine types, the history and age of the minefield, etc.

The trial was conducted in the particular soil conditions found at the ADP Training Centre, Moamba. The soil was hard but workable with few or no stones and minimal root systems. The vegetation had been cut back before the trial requiring only minimal clearance of short grass clumps. Timings are only relevant to the techniques used in the specific conditions at the trial site and, while timings for other conditions can be estimated by inference, trials in a range of different conditions are required to confirm this trial's results

## **Observations**

One ADP QA monitor apparently had an effect on the speed of the ADP deminers. The progress of any ADP deminer he was observing was noticeably slower than when being observed by other

monitors. This variation in the deminers' speed was evened out by rotating the monitors throughout the tests.

One of the deminers routinely worked much faster than the others.

The excavation method using the enxada was observed as being intrinsically dangerous due to the tendency to swing the enxada in order dig rather than scrap thinly slice the spoil and the method was considered as too dangerous.

## Results

The monitors recorded the timings of the key actions of the deminers as they cleared the lanes in each test. The minimum requirement was to record the following:

- Start and finish of work periods
- Time of the clearance of each metre
- Time and location of mines exposed
- Quantity and type (magnetic or non-magnetic) of metal fragments found

The additional detail recorded by the monitors varied. In some cases the location and time of metal detector signals and the approximate location of metal fragments found were recorded.

The monitors' records of timings and their comments were transposed daily and the complete set of records was distributed by Andy Smith after the trial.

In addition, the deminers were questioned to gather their perception and opinions on the various manual methods. Each deminer and section leader was asked the same set of questions for each test that they undertook. The results were recorded and retained by Andy Smith.

## Analysis

### Outline

An analysis of the timings has been undertaken in order to determine the relative rates of clearance of the different manual methods used and to understand the key elements in the demining process.

### Method

The timings recorded by the monitors were refined to remove non-clearance activities, e.g. rest periods, time taken for monitors to remove located mines, etc.

The pairs of 5m lanes cleared by each deminer in each test were combined to form one 10m area per deminer to provide an overall rate of advance for each deminer in each test.

The overall rate of advance (total area cleared ÷ total clearance time) was calculated for each test by combining the timings for both deminers in all four 5 m lanes.

The overall rates of advance for the various manual methods employed were compared and the number of mines found/missed, and the number of metal fragments found, were considered.

Where the monitors results allowed the clearance operation was broken down to identify the time spent excavating for the mines found.

### Results

The tables showing the timings for Tests 1, 2, 3, 6, 7 and 8 are at Appendices A to F respectively.

The overall rates of advance for each deminer are in

Table 1 below. It can be seen that although working in similar ground with the same tools, the same number of mines and the same amounts of metal fragments the deminers in individual tests worked at rates differing by between 8% and 86%. This variation in rate could be a result of the deminer's

experience, efficiency, procedures, attitude (including attitude to the trial) or, most likely, a combination of all factors. One deminer in particular, for whatever reason, was noticeably quicker than his colleagues his results are highlighted with an \* in

Table 1.

Ser	Test	Deminer	Rate of Advance (min/m <sup>2</sup> )	Comments
(a)	(b)	(c)	(d)	(e)
1	Test 1a	Lane 1 & 2	55.7	
2	Test 1b	Lane 3 & 4	44.1	
3	Test 2a	Lane 1 & 2	16.8*	
4	Test 2b	Lane 3 & 4	31.2	
5	Test 3a	Lane 1 & 2	13.0*	
6	Test 3b	Lane 3 & 4	19.6	
7	Test 6a	Lane 1 & 2	38.1	
8	Test 6b	Lane 3 & 4	41.1	
9	Test 7a	Lane 1 & 2	169.7	Lanes not completed
10	Test 7b	Lane 3 & 4	115.6	
11	Test 8a	Lane 1 & 2	26.2*	
12	Test 8b	Lane 3 & 4	36.6	

Table 1 - Deminers Rates of Advance

A comparison of the various manual methods is shown in

Table 2 below.

It can be seen that in Tests 1 to 3, which included the use of the metal detector the use of magnets to retrieve the magnetic metal fragments significantly speeds up clearance when compared with the standard ADP SOP method. The quickest method proved to be the magnetic rake.

Tests 6 to 8, which did not use metal detectors but required the excavation of the whole area were slower than the magnetic tool and detector methods with the rates for the spade and enxada being comparable but the NPA hand trowel excavation being extremely slow. It is of particular interest to note that the spade and enxada excavation methods with out detectors were both faster than the standard ADP SOP method with metal detector. This is probably because the standard ADP SOP method has to investigate every metal fragment detected, whereas the excavation method simply bypasses many metal fragments in the spoil. This is significant when considering effective QA methods for these techniques.

Ser	Test	Method	Rate of Advance (Min/m <sup>2</sup> )	Total Fragments found	Mines missed by deminer	Mines found by internal QA	Clearance Effectiveness
(a)	(b)	(c)	(d)	(e)	(f)	(g)	(h)
1	Test 1	ADP SOP	49.9	142	2	2	100%
2	Test 2	Magnetic Trowel	24.0	161	5	1	75%

3	Test 3	Magnetic Rake	16.3	148 (est)	2	1	94%
4	Test 6	Excavation - spade	39.6	16	0	0	100%
5	Test 7	Excavation - trowel	137.9	5	0	0	100%
6	Test 8	Excavation - enxada	31.4	15	1	0	94%

Table 2 - Manual Method Comparison

When the number of mines missed is considered, and not withstanding the fact that the lanes in Test 7 were not completed, it is evident that the excavation methods are the most effective at clearing mines. The one mine missed in the excavation tests was because the deminer's excavation veered away from the true lane edge thus missing the mine. The mine would have been found when the adjacent lane was cleared.

The magnetic trowel test missed the most mines, the majority of which were not found by the internal QA. It is noted that all the mines missed were deeply buried at 120mm. There are various possible reasons that these mines were missed, but it may be that either the deminer discounted the metal detector signal as too weak, or that the metal detector was poorly calibrated (N.B. the detector used for the internal QA was the same metal detector that the deminer used). These misses are significant in that they show a weakness introduced by the use of metal detectors when searching for relatively deep AP mines.

The relative efficiency of the techniques cannot be fully assessed with out a relationship defining the relative importance of clearance effectiveness and rate of advance. This relative weighting of these parameters will vary considerably depending on factors such as the future use of the mined land, and the acceptable residual risk. However, if it is assumed that the requirement is for no residual risk then the excavation methods are the most efficient and in this trial the enxada method is the most efficient but it is also potentially the most dangerous method.

In a few instances the time taken to expose and confirm mines once the metal detector had indicated a metal object was recorded by the monitors. Analysis of these timings enable the demining process to be broken down into constituent parts in order to further understand the system.

The system can be sub-divided into its constituent parts, for example the manual technique could be divided into four elements, as follows:

- Routine Clearance
- Excavation for a mine
- Rest periods
- Admin/Maint

The breakdown of timings for Test 1, Lane 1 and for Test 2 Lane 4 are shown in Table 3 below.

Ser	Lane	Rest (min)	Maintenance (min)	Mine Excavation (min)	Routine Clearance (min)	Total Time (min)
(a)	(b)	(c)	(d)	(e)	(f)	(g)
1	Test 1, Lane 1	180	0	28 (2 mines)	240 (30 frags)	448
2	Test 2, Lane 4	100	0	50 (3 mines)	87 (35 frags)	237

Table 3 - Clearance Breakdown

For the purposes of this analysis each rest break is assumed to be 20 minutes, including overnight breaks.

Of the five mines located in these lanes three were buried at 10mm and two were buried at 120mm. The shallow mines each took between 3min and 8min to expose and the deep buried mines took 25min and 35min to expose.

Excluding the rest periods and excavating times the comparison of routine clearance in Test 1 (without magnetic tools) and Test 2 (with magnetic trowel) can be made.

- Routine Clearance using ADP SOP method - 48min/m<sup>2</sup>
- Routine Clearance using a magnetic trowel - 17min/m<sup>2</sup>

## **Conclusions**

The effects of the differing skills and abilities of the deminers were not taken into account in this trial.

The specific results from this trial apply to the specific conditions that were encountered in the trial lanes at ADP Training Centre in Moamba in Mozambique.

The excavation methods without metal detectors using the spade and enxada are quicker than the ADP SOP clearance method because the metallic scrap does not have to be cleared when excavating the whole mine lane.

The use of magnets attached to clearance tools significantly speeds up the rate of advance when compared with either the standard ADP SOP method or the excavation methods because the magnets remove the surface and shallow magnetic scrap metal fragments.

Excavation methods are less likely to miss deeper buried mines than methods using metal detectors.

## **Recommendations**

Further trials are required in order to complete the analysis of manual demining techniques and to validate the results by conducting all tests with more deminers and in a variety of environmental conditions.

Further data is required to fully understand the breakdown of the constituent parts of the clearance processes.

## Annex E: BAM trial report

[This report was received in February 2005 and so its content is not fully reflected in the body of the AVS report.]

### Report on comparative trails in Mozambique – BAM

#### A1 BAM Results of Trials 1-8, Speed

This annex compares the speeds of eight manual demining methods tested in the trials. Eight trials were performed, each trial using one manual demining method, see Table 4: List of all trials.

Table 4: List of all trials.

- Trial 1: Metal detector and standard tools
- Trial 2: Magnetic trowel
- Trial 3: Magnetic brush-rake
- Trial 4: Metal detector reliability test
- Trial 5: REDS rake system
- Trial 6: ADP spade excavation
- Trial 7: NPA short tool excavation
- Trial 8: Enxada excavation
- Trial 9: Prodder

Each trial was performed on four five-metre lanes. In each 10-metre test area (comprising two five metre long lanes) eight targets had been buried to random positions, keeping their mutual distance larger than 50cm. Targets were four Type-72 surrogates and 4 GYATA-64 surrogates, two of each type buried to two depths, 1 cm and 12 cm. The description of the targets is given in Annex C.

The trials were performed by the personnel listed in Table 5.

Table 5: Deminers performing the trials.

trial	lane	deminer	team	section commander
1 (standard)	1, 2	Carlos Tembe	1	Fernando Laice
	3, 4	Helder Martins Afido		
2 (mgn. trow.)	1, 2	Januario Justino Mindo	2	Dionisio Chaka
	3, 4	Julio Ernesto Wache		
3 (mgn. rake)	1, 2	Januario Justino Mindo	2	Dionisio Chaka
	3, 4	Julio Ernesto Wache		
4 (no frags)	1, 2	Julio Ernesto Wache	2	Dionisio Chaka
	3, 4	Januario Justino Mindo		
5 (REDS)	1, 2	Carlos Tembe + Helder Martins Afido	3	Fernando Laice
	3, 4	Januario Justino Mindo		
6 (spade)	1, 2	Helder Martins Afido	1	Fernando Laice
	3, 4	Carlos Tembe		
7	1, 2	Quisito Armando	4	Nuno Satar

(NPA)	3, 4	Joao Horacio		
8	1, 2	Januario Justino Mindo	2	Dionisio Chaka
(enxada)	3, 4	Julio Ernesto Wache		
9	1	Carlos Tembe	1	Fernando Laice
(prod)	2	Helder Martins Afido		

For a reliable comparison between two trials (two methods), some confidence bounds need to be attributed to the average result of each trial. Confidence bounds give an estimate of an outcome of the repeated experiment (“repeated” means that all known conditions of the experiment are exactly replicated). Results of these trials are presented in Table 6 and a summary of that table in Table 7. A graphical overview of the results is given on a diagram on Figure 4.

All results are presented in terms of average time needed to clear a square metre of a given area. Each lane is divided to four or five approximately equally large areas (called “parts” in Table 6) to give the information about the scattering of the results within the same trial. Trials 5 and 7 were not completed. The rows of Table 6 labelled “average”, “standard deviation” and “standard deviation of the mean” are calculated from the numbers above them, which do not contain the time spent on quality assurance. Quality assurance (QA) is listed separately in that table, and the total result which includes QA is listed at the bottom of the same table (“with QA: average”). Results of the whole system (deminer + QA) are presented once more in a short summary on Table 7 and on a diagram on Figure 4.

The time spent on QA was estimated based on incomplete monitor notes, but the maximum possible error of these estimates is considerably smaller than the estimated standard deviation of the mean listed in Table 6, so that this error can be neglected.

Table 6: Results of trials 1-8.

			Trial								
			1	2	3	4	5	6	7	8	
Lane	1	part	1	60	11.7	11.6	20.7	107	69	104	22
			2	28.7	9	10.5	12.7	105	43	242	23
			3	57.7	49	13.1	6.09	145	47	230	23
			4	79.1	21	2.73	13.6	44.6	53		29
			5					79.5	46		31
	2	part	1	138	16.5	11.8	19.7	110	53		26
			2	31.2	10	8.18	29.2	145	29		23
			3	20.8	7.33	18.5	15.6		36		35
			4	36.8	11.3	18.6	9.03		28		24
			5						23		13
	3	part	1	135	57.9	12.2	32.4	138	70	159	56
			2	37.3	13.1	21.3	15.1	67	85	142	54
			3	25	28.9	16.9	3.1	80.4	49	74.4	41
			4	17.5	32.9	15	6.07	96.4	37	101	22
			5						36	109	30
	4	part	1	42.7	40	22.5	16.5		49		32
			2	54.5	49.2	15	11.5		56		25
			3	17.2	12.7	38.2	7.08		38		27
			4	35.8	7.27	17.3	10.3		40		32
			5						22		34
average			51.1	23.6	15.8	14.3	102	45.5	145	30.1	
standard deviation			37.4	17.1	7.78	8.14	32.5	16.1	61.8	10.4	
st. dev. of the mean			9.35	4.26	1.94	2.03	9.8	3.61	21.8	2.34	
QA			4	2	4	4	4.5	0.4	0	0	
with QA: average			55.1	25.6	19.8	18.3	106	45.9	145	30.1	

Table 7: Summary of the results.

		Trial							
		1	2	3	4	5	6	7	8
with QA: average		55	26	20	18	106	46	145	30
st. dev. of the mean		9	4	2	2	10	4	22	2

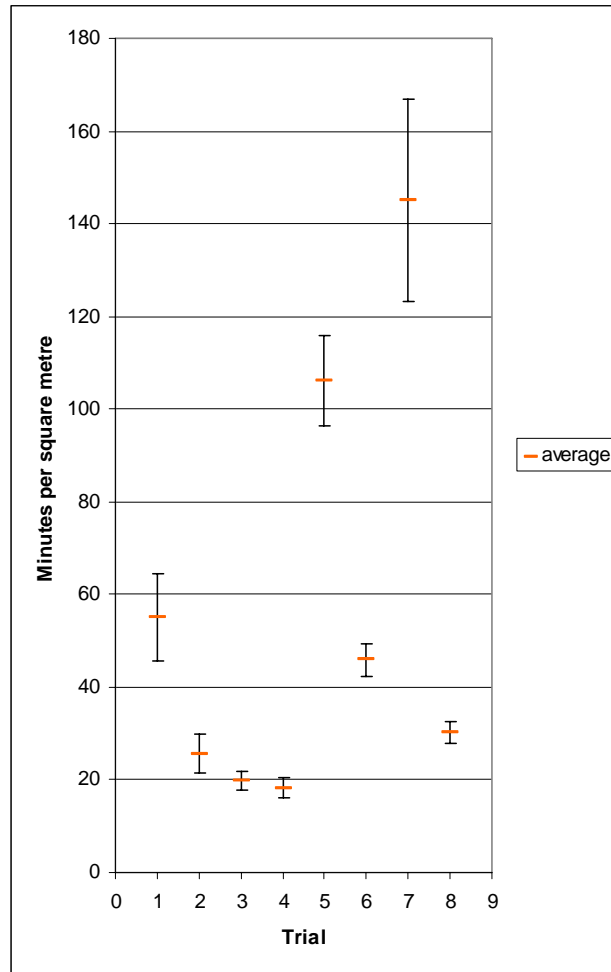

Figure 4: Overall results.

Results of these trials should be interpreted carefully. If the goal is comparing methods, than all conditions of their application that may influence the results should be the same for all methods. Conditions of application are not just the physical environment, e.g. soil, but also the personnel. Every trial should approach this ideal, however, that is hardly achievable in practise due to limited resources. In these trials methods were not tested by the same persons. Individual differences between deminers were obvious during the trials and they certainly have some influence on the results. Even the choice of monitors influenced the way the deminers worked and consequently their speed. All these disadvantages can be minimised with a better trial design, which is discussed in Annex B.

Variation of the speed within a lane is illustrated on a diagram on Figure 5. Values of the reciprocal of speed (time per area) are taken from Table 6. This variation is described with the standard deviation also listed in Table 6.

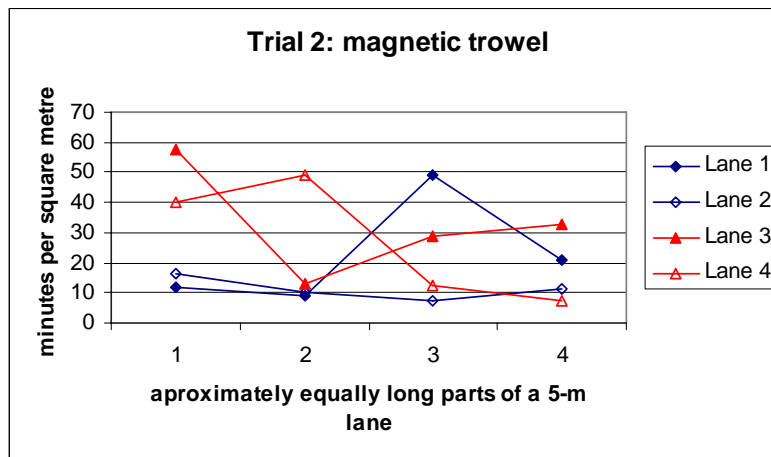

Figure 5: Example of the variation of speed within a trial

Positions of the targets certainly influenced the speed, especially with the methods using metal detectors. However, this factor cannot explain high variations of speed, since its contribution to the variation is much smaller than the standard deviation. Example on Figure 5, lane 1, illustrates this clearly: two mines were laid in part 2, one in part 3 and one in part 4, nevertheless the least time was needed to complete the part 2. High variations of the speed can be explained with heterogeneous properties of the test lanes and with the inconstant behaviour of human beings. Soil is heterogeneous: it contains stones, roots, etc., soil hardness is not uniform, metal fragments can be found on all depths. Most of these factors are uncontrolled, but their influence can be minimised with an appropriate trial design (see Annex B).

Some conclusions can be made based on compelling inferences. All these conclusions that will follow are valid only if the conditions in a minefield are similar to the conditions in the test areas, the most important being the properties of soil and distribution of metal fragments. In some other conditions results of the trials would be different. Experienced deminers' opinion about the possible advantages of each method in other conditions of application could be a very valuable guide (see Annex <sup>\*\*\*</sup>, Questionnaire)

Results of these trials indicate that the use of tools with magnets would significantly increase the speed of demining when used in combination with metal detectors. They also indicate that the excavation methods of trials 5 (REDS) and 7 (NPA short tool) would be considerably slower than other methods. It can be also inferred that the method of trial 6 (spade) would probably be faster than the ADP standard use of metal detectors, which is the method of trial 1. It can be concluded with a higher certainty that the method of trial 8 (enxada or mattock) would be faster than the method of trial 1.

Safety of the methods is not assessed in this report.

## A2 Results of “reliability trial” (Trial 4)

Trial 4 consisted of two parts. The first part was a so called reliability trial of a metal detector, and the second part was a full trial with investigation of each signal. The results of the second part are described in Section A1 of this report. This annex presents the results of the reliability trial.

Detection reliability tests are described in the CEN Workshop Agreement CWA 14747:2003. (available at <http://humanitarian-security.jrc.it/demining/cw07/>). In a reliability test, targets are placed in metal free lanes at positions not known to detector operators. While scanning, the operators mark the places of indications and, later, supervisors measure and record the spatial coordinates of the markers.

Some argued that the results of a full process (including investigation of each signal) would always be higher than the results of a reliability test. Results of these trials do not confirm such a prediction.

Each deminer made a pass over two lanes leaving markers on the positions of indications. Position of these markers were measured and compared with actual positions of the targets. A target is considered to have been detected when a marker is dropped within a prescribed radius (“halo”) around the true target location. Halo radius of the GYATA-64 surrogate is 15cm and of the Type-72 surrogate 10cm. These results are presented in the third column of Table 8 (column labelled “reliability

trial”, “deminer”). After that, without removing the markers, the Section Commander checked the deminer’s indications. He removed some of them, deciding that they do not indicate presence of a metal object, he moved some markers to improve pinpointing and he added some if he thought that the deminer missed a target. His results are presented in the same table in the adjacent row.

The full trial was performed afterwards. The deminers proceeded with their work as in the other trials, investigating each signal. Results of that part of the trial are presented in the last two columns of Table 8, labelled “full trial”.

As seen from the table, in reliability trials one of the Type-72 surrogates was missed by the deminer, but found by the section commander. In a full trial even two such cases occurred. It has been noticed that in most cases there are two indications in proximity of the GYATA surrogate, sometimes both lying outside of the halo. Such a case is highlighted in the table with red colour. It is interesting that the section commander moved one of the markers a few centimetres away from the middle of the target, thus putting his marker just outside of the halo, so it appears that he missed something what was found by the deminer. There are some indications that a real GYATA-64 also produces two signals, although that was not noticed during the maximum detection distance measurements (see Annex C). Since this same mine was found in the full trial, these results indicate the need for improvements of the current concept of the halo radius.

Table 8: Results of trial 4

		reliability trial (1 = detected, 0 = not detected)		full trial (1 = detected, 0 = not detected)		
target	depth	deminer	section commander	deminer	section commander	
Type-72	1	1	1	1	1	
		1	1	1	1	
		1	1	1	1	
		1	1	1	1	
	12	1	1	1	0	1
		1	1	1	1	1
		1	1	1	1	1
		0	1	0	1	1
GYATA-64	1	1	1	1	1	
		1	1	1	1	
		1	1	1	1	
		1	1	1	1	
	12	1	1	1	1	1
		0	0	1	1	1
		1	1	1	1	1
		1	0	1	1	1

Apart from the GYATA surrogate that was counted as not detected in the reliability trial due to reasons mentioned above, there are no essential differences between the results of these reliability trials and the full trial.

### A3 Targets used in the trials

Targets in the trials were surrogates of mines Type-72 and GYATA-64. They were designed as wooden cylinders of approximately the same size as the real mines, with a bore inside, where a metal piece was placed. Mine surrogates are illustrated on **Error! Reference source not found.** and **Error! Reference source not found.**

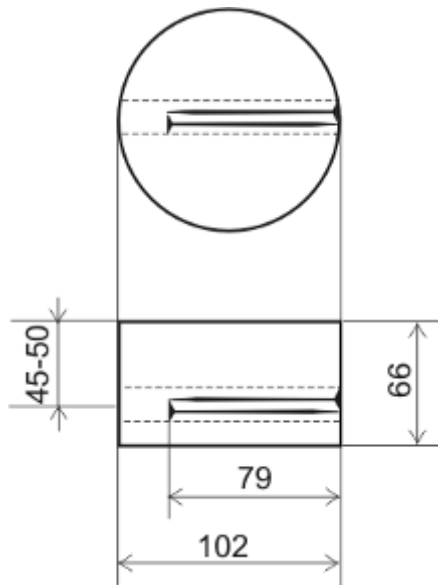

Figure 1: Surrogate of GYATA 64

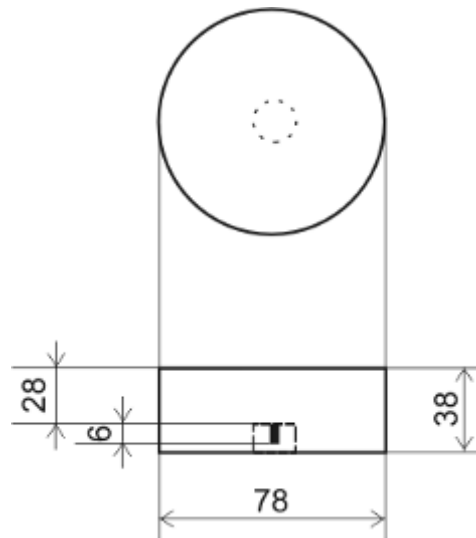

Figure 6: Surrogate of Type-72

Metal parts were chosen so that the maximum detection distance (MDD) with the Minelab metal detector is approximately the same as the MDD of the corresponding mine. In the GYATA-surrogate two nails were used and in the Type-72-surrogate a piece of steel wire (indicated black on figures). They were fixed to the wooden bodies of the surrogates with a piece of BlueTack.

Results of MDD measurements are listed in the following tables. Measurements were performed by Mate Gaal and Manuel Django.

Measurements presented in Table 9 were performed on five different surrogates (the right column) and the three repeated measurements on a real mine Type-72 (left column) were performed on the same target.

Measurement presented in Table 10 was performed by moving the mine against the search-head of the metal detector in a direction perpendicular to the direction of the firing pin, while the surrogate was moved perpendicular to the direction of the nails.

Measurements presented in Table 11 were performed by moving the mine against the search-head of the metal detector in a direction parallel with the direction of the firing pin, while the surrogate was moved parallel with the direction of the nails.

These measurements indicate that the direction of approach to the mine has an influence on the size of the signal.

Table 9: MDD measurements on Type-72.

MDD (cm) Type 72	MDD (cm) surrogate
15	16
15	15

15	16
	17
	15

Table 10: MDD measurements on GYATA-64, moved perpendicular to the firing pin.

MDD (cm) GYATA 64	MDD (cm) surrogate
19	20

Table 11: MDD measurements on GYATA-64, moved parallel with the firing pin.

MDD (cm) GYATA 64	MDD (cm) surrogate
22	24
22	24

**A4 BAM Proposals for improved trial design and data evaluation**

With a little more investments in resources, high gains can be achieved, if the trials are carefully planned and designed in advance. This annex should be read as a continuation of the Annex A, which presented some results of the trials and some interpretation of the results.

It has been shown in many metal detector trials that the influence of the human factor is very significant. The same has proven to be true in these manual demining trials. To compare the methods efficiently, each method should be tested with the same deminers and the number of deminers should be as large as possible. Other controlled conditions should be treated in a same way. For example, if two methods need to be compared, they should be performed at the same time if possible. If Method 2 would be performed a day after Method 1, many uncontrolled factors might influence the results (e.g. rain during the night).

It is impossible to assure that all conditions are the same for all methods tested, but it is possible to minimise the impact of the uncontrolled factors by randomising the design. This is illustrated by the following example. If two methods would need to be compared and each method would be tested in four lanes, than the location of the lanes on a testing area should be random or quasi-random. Grouping four lanes for Method 1 together would not be the best choice, because there might be a systematic difference between the soil on that area and the soil elsewhere. A possible choice is illustrated in Table 12.

Table 12: Possible randomisation of lane positions

Method 1		Method 2		Method 1		Method 2
Method 2		Method 1		Method 2		Method 1

A more complex multivariable data analysis would give more insight in the influence of the density of mines, time of day, etc. However, influencing variables need to be defined before the trials are designed and they should guide the design, so that the results can be used in the analysis.